

**TECHNICAL GUIDE
&
PARTS CATALOGUE**

**Cal.VJ22A/B
Cal.VJ24A/B**

ANALOGUE QUARTZ

SII Products

VJ22A/B VJ24A/B

[SPECIFICATION]

Version-01

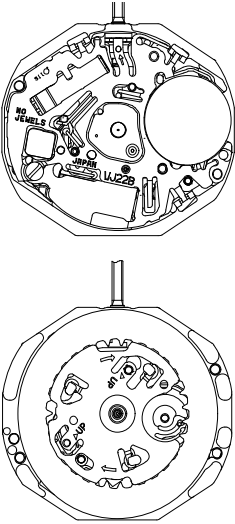
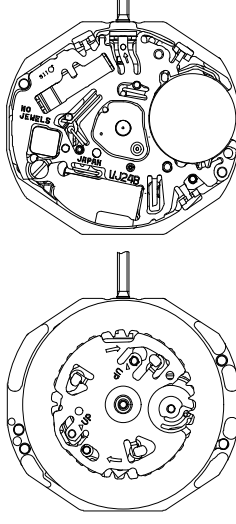
Item		Cal. No.	VJ22A/B	VJ24A/B
Movement				
Movement size	Outside diameter		$\phi 18.50$ mm 18.20 mm : between 12 o'clock and 6 o'clock sides 16.10 mm : between 3 o'clock and 9 o'clock sides	
	Casing diameter		$\phi 18.10$ mm 17.80 mm : between 12 o'clock and 6 o'clock sides	
	Total height		2.71 mm (including the battery)	
Time indication			3 Hands Calendar	2 Hands Calendar
Driving System			Step motor (Load compensated driving pulse system type)	
Additional mechanism			Electronic circuit reset switch Second setting device Date setting	Electronic circuit reset switch Date setting
Loss/Gain (Monthly rate) Frequency of crystal oscillator			Less than ± 20 seconds at normal temperature range 32,768 Hz	
Operational temperature range			- 5°C ~ + 50°C	
Regulation system			Nil	
Measuring gate by quartz tester			Use 10-second gate * Set the winding stem with crown at the normal position	
Battery			SR621SW (Silver oxide battery) Battery life is approximately 3 years	
Jewels			0 Jewel	

Disassembling procedures Figs. ① → ②⑧

Reassembling procedures Figs. ②⑧ → ①

Lubricating : Types of oil

- Moebius A
- Moebius F

Oil quantity

∞ NORMAL QUANTITY

*Refer to the 4pages for the each parts code

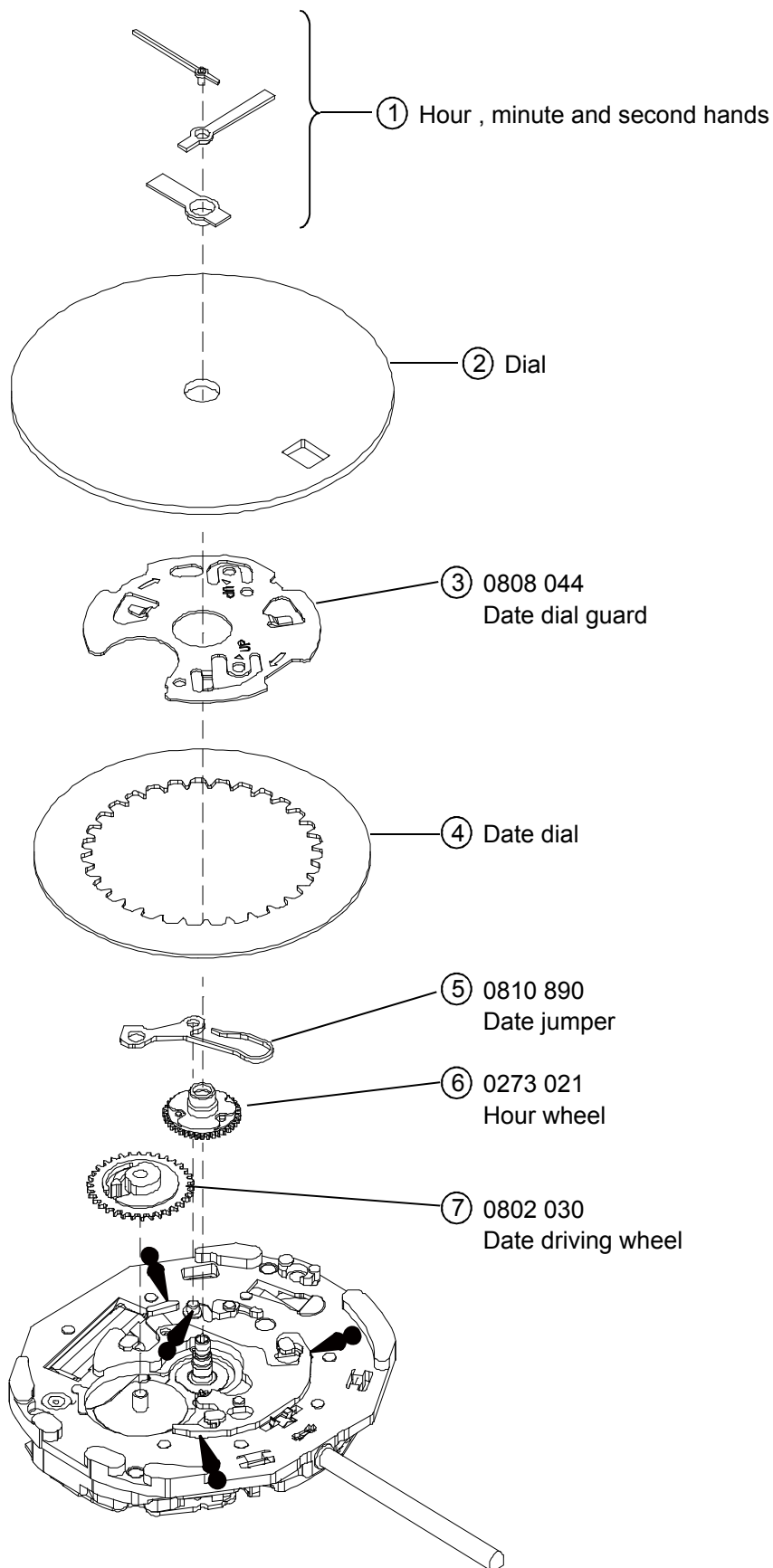

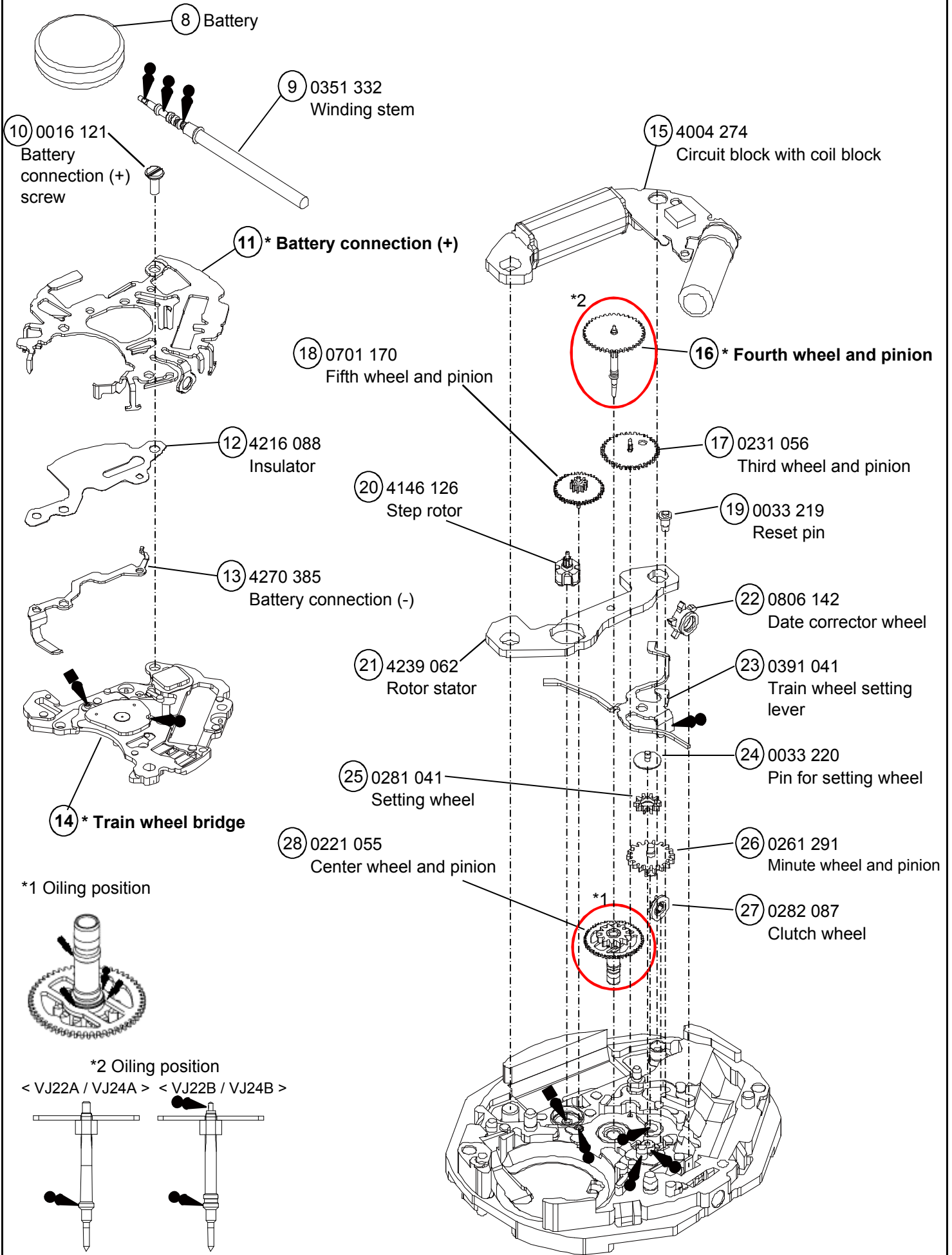

*Refer to the 4pages for the each parts code

Remarks:

④ Date dial

Part code	Positing of crown	Positing of date frame	Color of figure	Color of background
0878 152	3H	3H	Black	White
0878 155	3H	3H	White	Black
0878 160	3H	6H	Black	White
0878 161	3H	6H	White	Black

○ The part which is not common in Cal.VJ2*A and Cal.VJ2*B

Parts name	VJ22A	VJ24A	VJ22B	VJ24B
⑪ Battery connection(+)	4271 192	4271 267	4268 036	4268 044
⑭ Train wheel bridge	0125 262	0125 262	0125 297	0125 297
⑯ Fourth wheel and pinion	0241 248	0241 280	0144 097	0144 088

***All parts cord are subject to change without notice.**

The explanation here is only for the particular points of Cal.VJ22 / VJ24

1. STRUCTURE OF THE CIRCUIT BLOCK

Notes: Since the circuit block and coil block are made by one piece, in disassembling and reassembling take care not to cut the coil line.

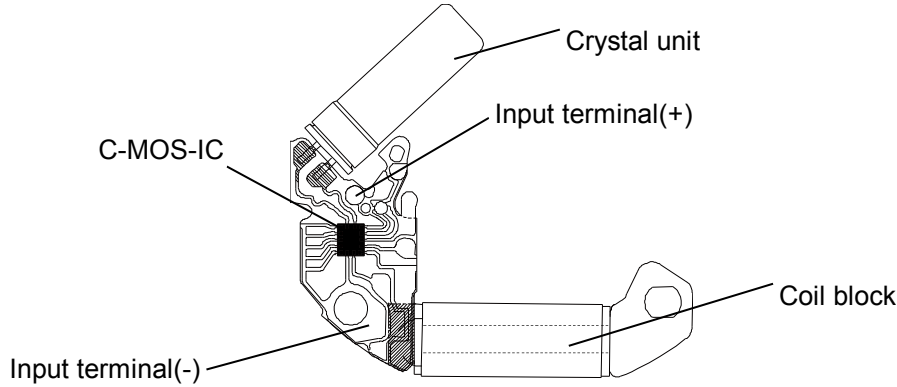

2. REMARKS ON DISASSEMBLING AND REASSEMBLING

- ① Hands
How to install
Place the movement directly on a flat metal plate or the like to install the hands.

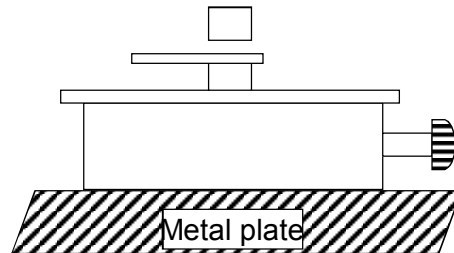

- ② Date dial guard
The date dial guard has three protrusions to be caught under the main plate, and it is also fixed by two guide pins.

•How to remove

- 1) Lightly lift the A portion of the date dial guard with tweezers to release it from the guide pin, and then move it in the clockwise direction until it gets off the guide pin.
- 2) Release the B portion of the date dial guard in the same way as described above, and then move it in the clockwise direction until gets off the guide pin.
- 3) Check that all the three protrusions of the date dial guard have come off from the main plate, and then remove the date dial guard.

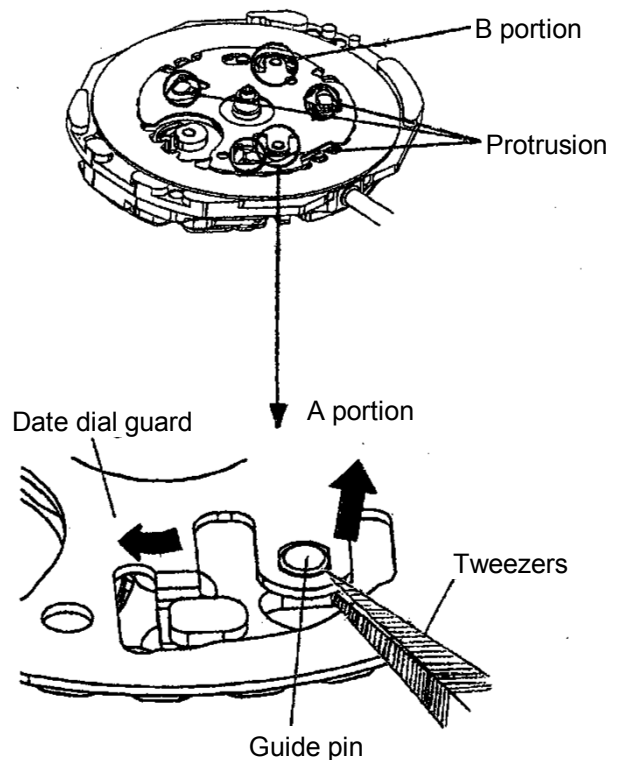

•How to install

- 1) Put the date dial guard on the main plate so that the A and B portion are over the guide pins, as shown in the illustration at right.
- 2) Move the protrusion D of the date dial guard in the counterclockwise direction so that it is caught under the main plate.
- 3) Slightly move the protrusions C and E in the counterclockwise direction alternately to set them under the main plate. Then, set the A and B portions of the date dial guard to the guide pins.
- 4) Check that the date dial guard is fixed securely to the main plate.

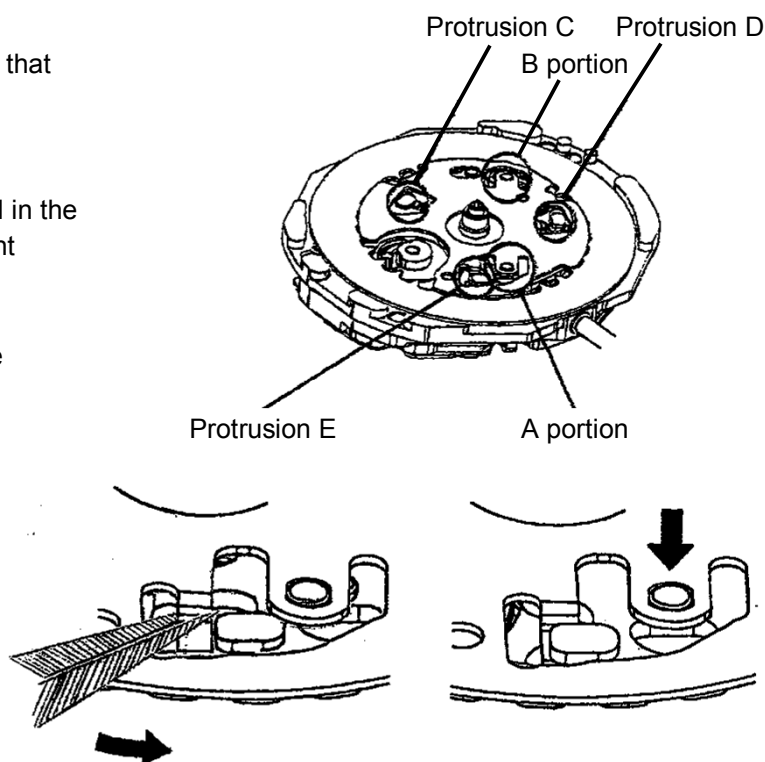

③ Battery

•How to install battery

Insert the Battery aslant in the direction shown by the arrow.
Check the Battery connection (+) securely touches the side face of the Battery.

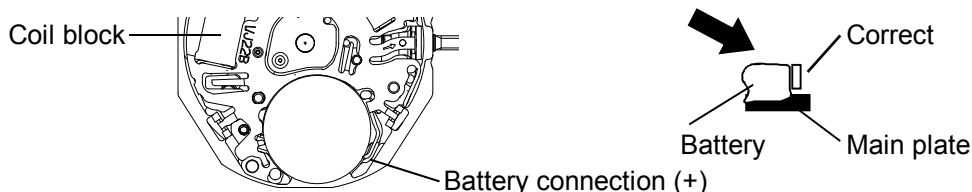

④ Battery connection (+)

•How to install

Have the hook portions (3 places) catch the main plate (Fig.1 & Fig.2).
In disassembling and reassembling, take care not to deform the hook portion.
After installing the Battery connection (+), check that the three hook portions securely catch the main plate.

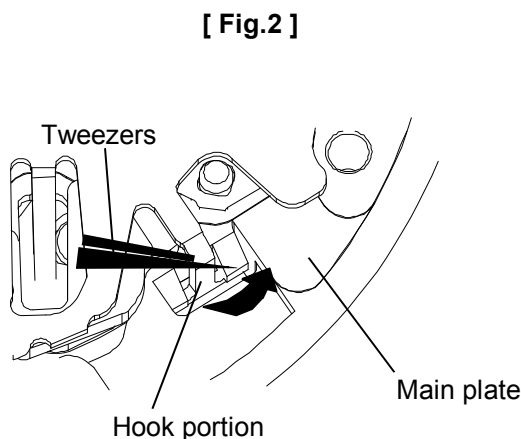
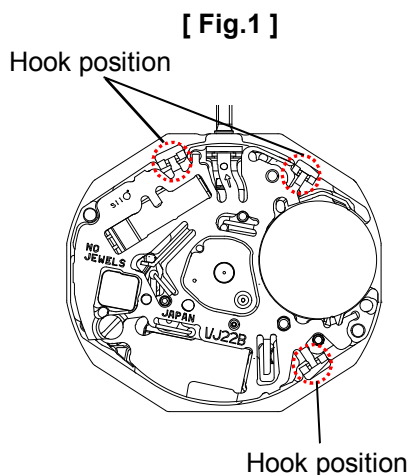

⑤ Insulator

- Setting position

Notes: To Insulate between the Battery connection (+) and the Battery connection (-), Insulator should be put at the three pin securely as bellow.

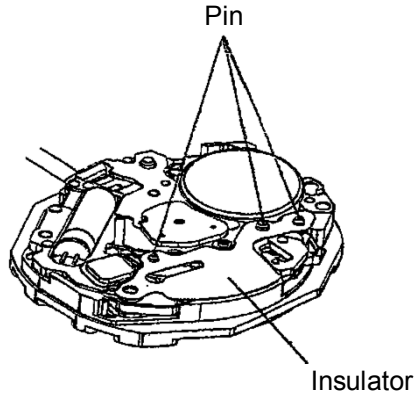

⑥ Train wheel bridge

- Setting position

Notes: Since the fifth wheel and pinion and step rotor are made of plastics, take care not to damage them in disassembling and reassembling.

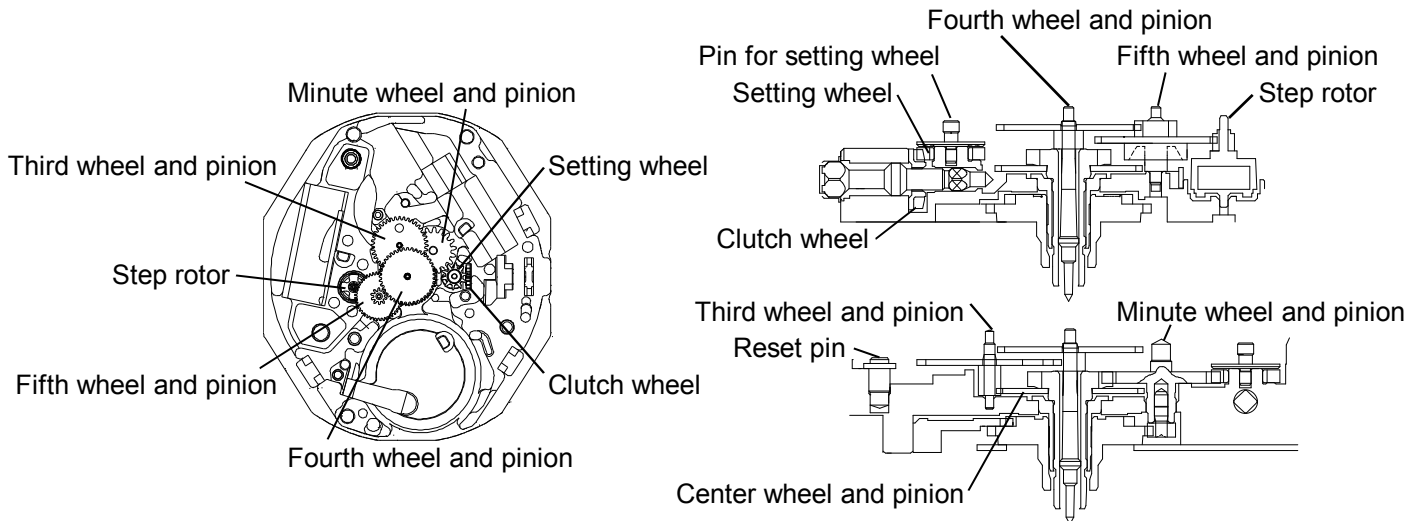

⑦ Train wheel setting lever

- Setting position

Notes:

- Catch the part of spring of the Train wheel setting lever to the pin like as below.
- Take care not to deform the spring portion of the Train wheel setting lever.

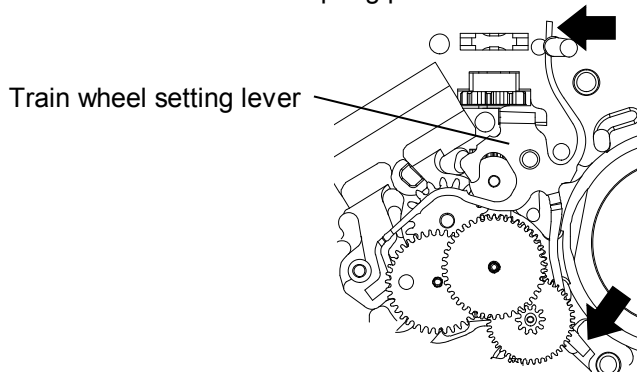

⑧ Pin for setting wheel

Notes:

In disassembling and reassembling, take care not to damage the portion that is assembled of the pin.
(Since the portion that is assembled of the pin is made of plastics and easily damaged.)

In disassembling,
pick the pin up main plate to vertical direction with care .

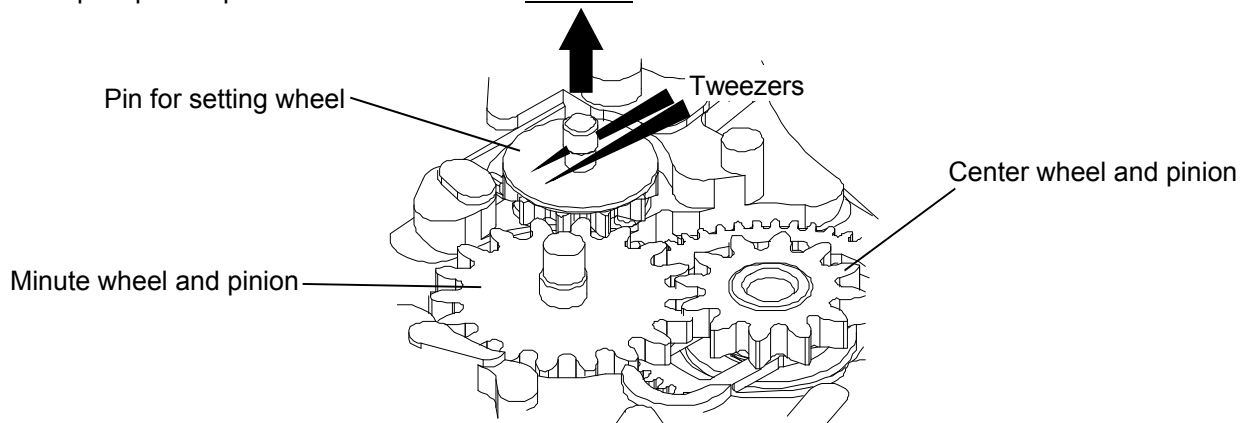

In reassembling,
push the pin in main plate to vertical direction with care .

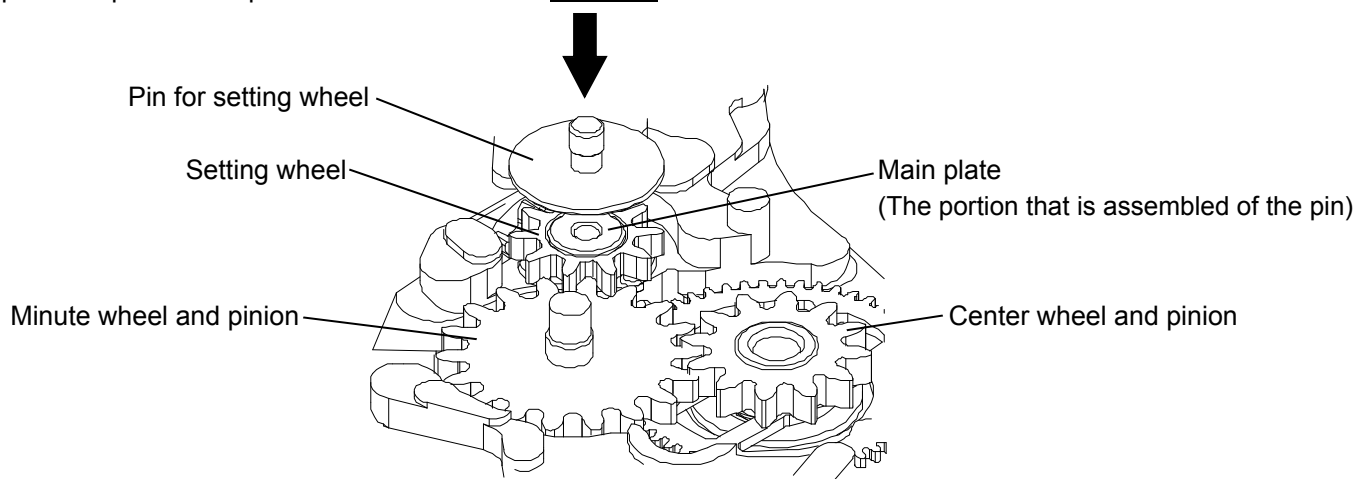

III. VALUE CHECKING

Coil block resistance	2.10KΩ~2.30KΩ
Current consumption	
For the wheel of the movement	less than 0.96μA