

**TECHNICAL GUIDE
&
PARTS CATALOGUE**

Cal.VB20B

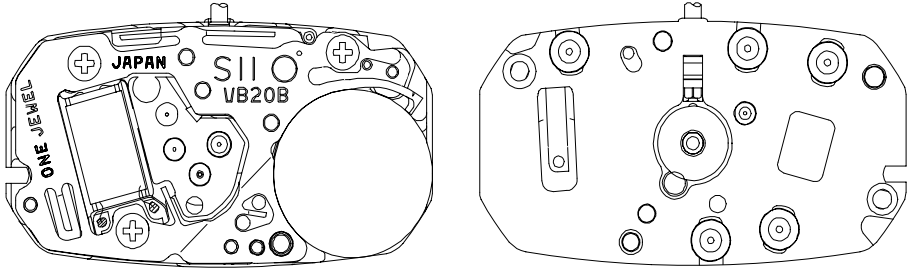

ANALOGUE QUARTZ

SII Products



Item		Cal. No.	VB20B
Movement (Appearance)			
Movement size	Outside diameter		15.55 mm : between 12 o'clock and 6 o'clock sides 8.45 mm : between 3 o'clock and 9 o'clock sides
	Casing diameter		15.15 mm : between 12 o'clock and 6 o'clock sides
	Total height		2.38 mm (including the battery)
Time indication			2 Hands (Move at 20-second intervals)
Driving System			Step motor (Fixed-width pulse system type)
Additional mechanism			Electronic circuit reset switch
Loss/Gain (Monthly rate) Frequency of crystal oscillator			Less than 20 seconds at normal temperature range 32,768 Hz
Operational temperature range			-5°C ~ +50°C
Regulation system			Nil
Measuring gate by quartz tester			Use 10-second gate
Battery			SR521SW (Silver oxide battery) Battery life is approximately 3 years Voltage : 1.55V
Jewels			1 Jewel

Disassembling procedures Figs. ① ⇒ ②⑥
 Reassembling procedures Figs. ②⑥ ⇒ ①

Lubricating : Types of oil Oil quantity

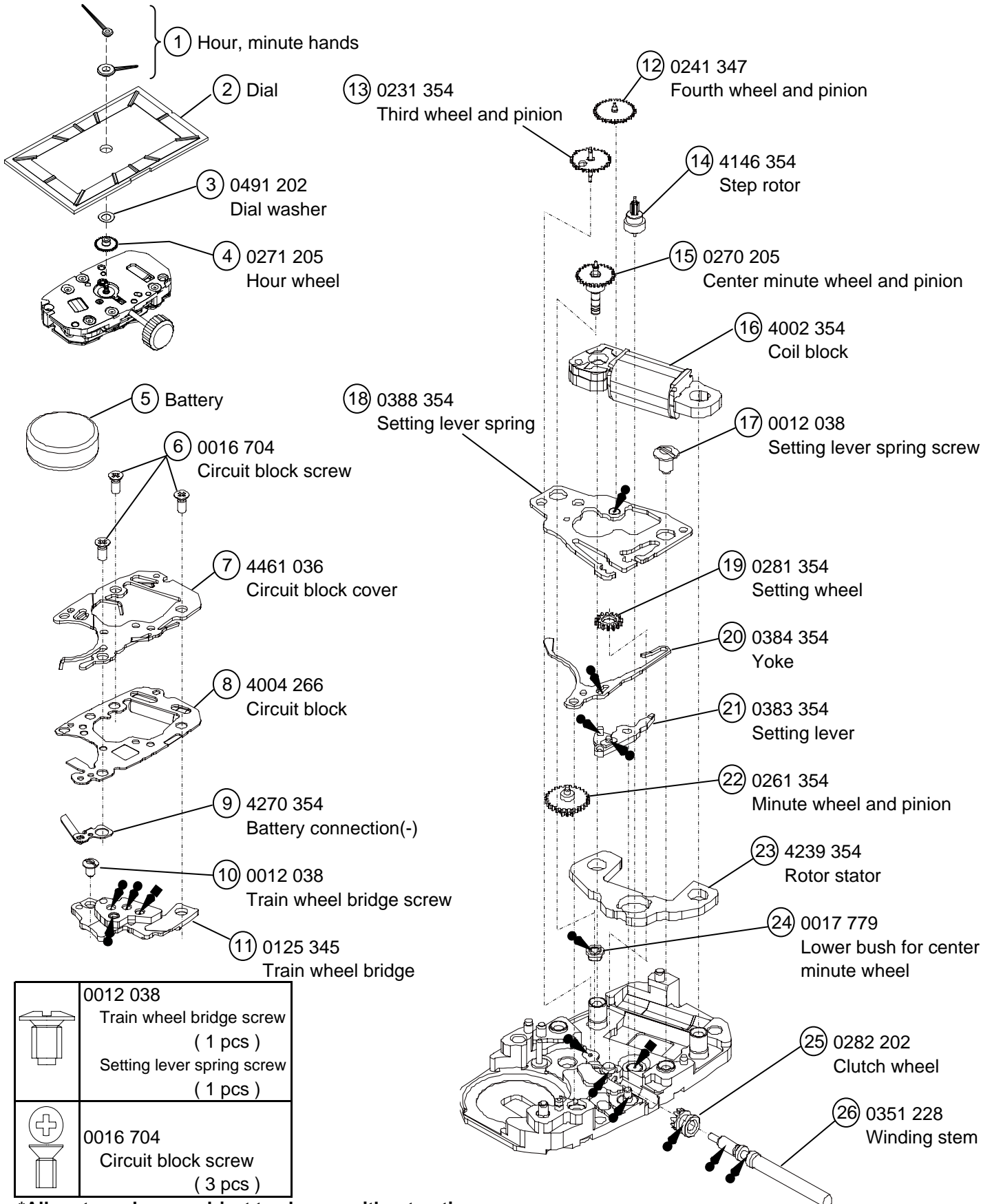
 Moebius A  Normal quantity
 Moebius F



	0012 038 Train wheel bridge screw (1 pcs) Setting lever spring screw (1 pcs)
	0016 704 Circuit block screw (3 pcs)

*All parts code are subject to change without notice.

• The explanation here is only for the particular points of Cal.VB20B

1. STRUCTURE OF THE CIRCUIT BLOCK

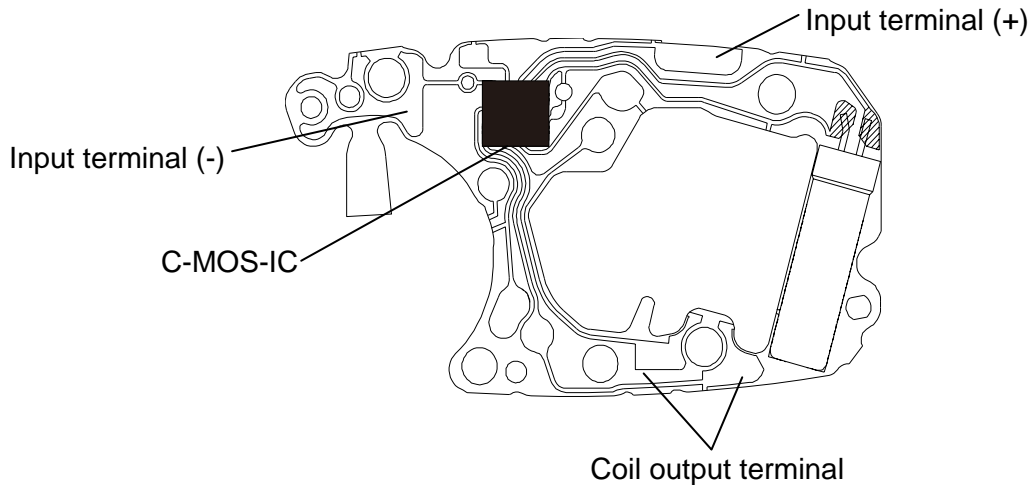

2. REMARKS ON DISASSEMBLING AND REASSEMBLING

- ① Hands
< How to install >
Place the movement directly on a flat metal plate or the like to install the hands. In doing so, make sure that the spring portion of the circuit block cover is not pressed.

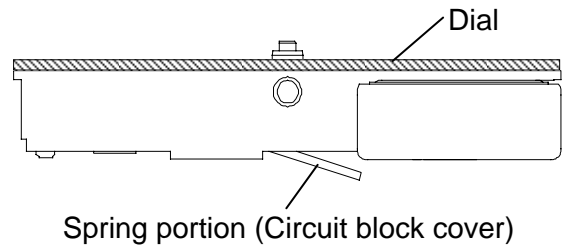

- ⑭ Train wheel bridge
< Setting position >

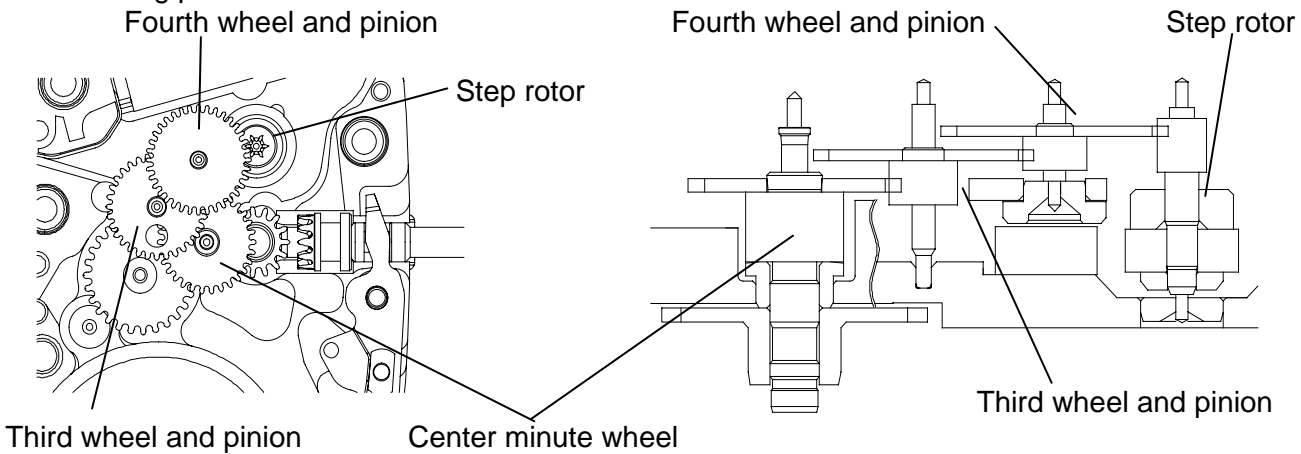

- ⑳ Winding stem 0351 208 (Φ 80) / 0351 228 (Φ 90)
The type of Winding stem is determined based on the design of case.

3. VALUE CHECKING

Coil block resistance 1.8kΩ~ 2.0kΩ

Current consumption
For the whole of the movement Less than 0.6μA