

TECHNICAL GUIDE AND PARTS LIST

CAL. V230A

ANALOGUE QUARTZ

CONTENTS

I. SPECIFICATIONS	1
II. DISASSEMBLING, REASSEMBLING, LUBRICATING	2
III. CHECKING AND ADJUSTMENT	5
1 Structure of circuit block	5
2 Procedure for checking and adjustment	5
A. Output signal	5
B. Battery voltage	5
C. Battery conductivity	5
D. Circuit block conductivity	5
E. Front gear train mechanism	6
F. Rear gear train mechanism	6
G. Reset condition	6
H. Current consumption	6
I. Accuracy	7
J. Water-resistant quality	7
K. Appearance and functioning	7
IV. PARTS LIST	8

I. SPECIFICATIONS

Item	Cal. No.	V230A
Time indication		Two hands
Additional mechanism		Electronic reset switch
Loss/gain		Monthly rate: Less than 20 seconds at normal temperature range
Size of main plate		φ15.5 (6H - 12H) × 13.0 (3H - 9H)
Casing diameter		φ15.1
Height		2.4 mm (including battery)
Quartz tester measuring gate		10-second gate
Battery		SEIZAIKEN TR521 SW Voltage: 1.55V Battery life: Approx. 3 years
Jewels		2 jewels

II. DISASSEMBLING, REASSEMBLING AND LUBRICATING

Disassembling procedures: Figs. ① → ⑳

Reassembling procedures: Figs. ㉗ → ①

● Hands ~ Hour wheel

Lubricating

Types of oil	Oil quantity
○ Moebius A	○ Normal
● Seiko oil S-6	○ Small amount

② The dial legs are inserted into the holes in the dial spacer and winding stem cock.

* To remove the dial, insert a small screwdriver into the notches for dial removal of the main plate (2 portions) and lift the dial out.

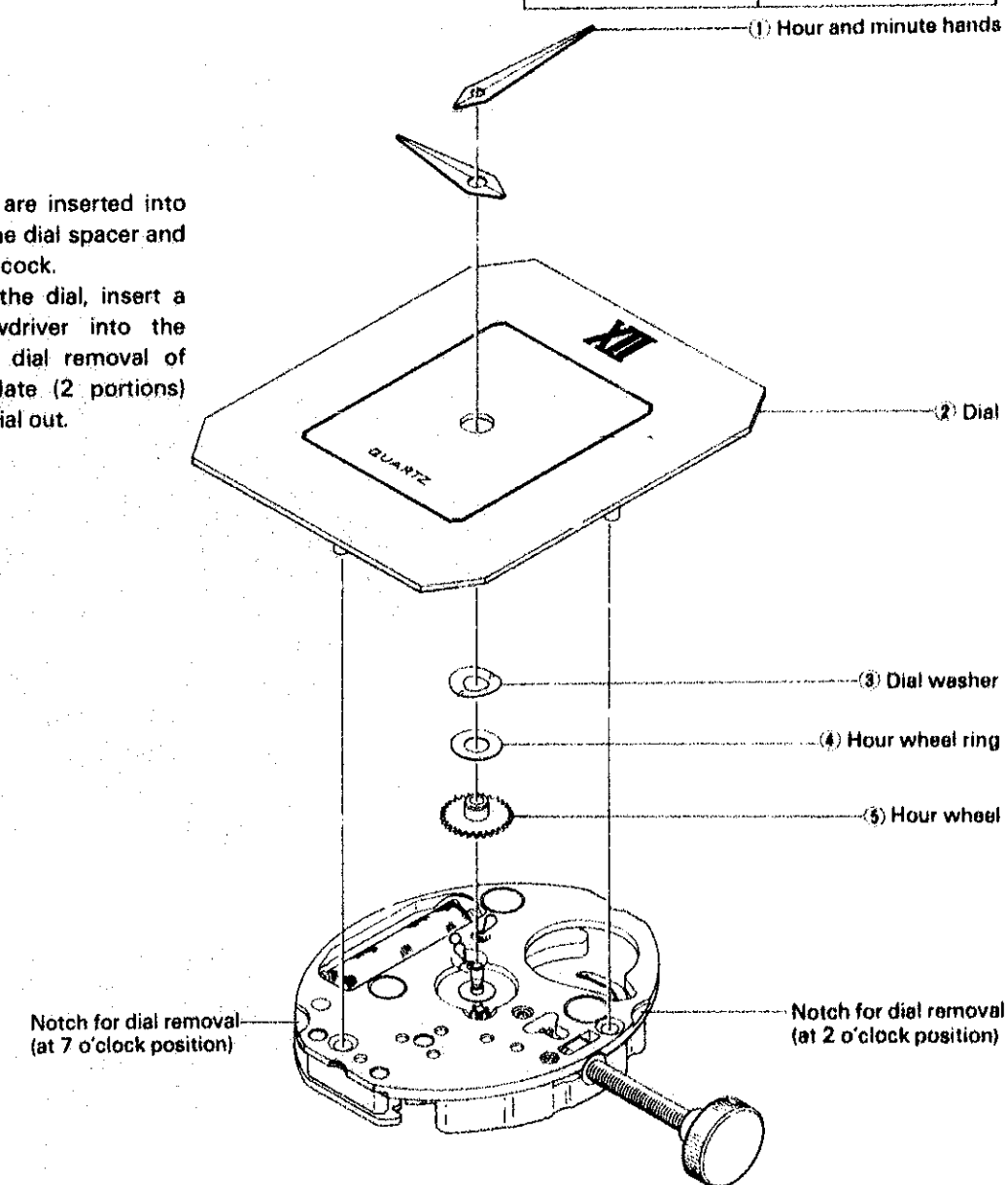



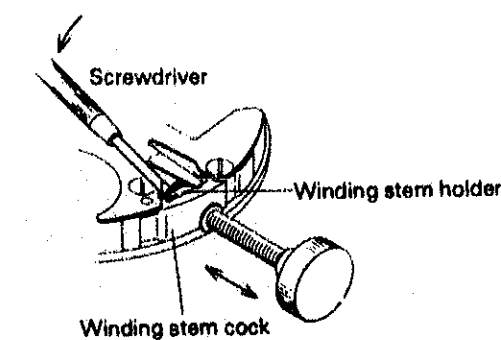

* Removing/installing winding stem

Insert a screwdriver in the direction of arrow between the winding stem holder and winding stem cock and pull out the winding stem while lifting up the winding stem holder.



● Screw for battery connection ⊕ ~ winding stem

List of screws used

Shape	Name	Parts No.
	Train wheel bridge screw (1 pce.)	012 495
	Screw for battery connection (A) (2 pcs.)	012 818
	Screw for battery connection (B) (1 pce.)	012 819
	Screw for circuit block (1 pce.)	012 496

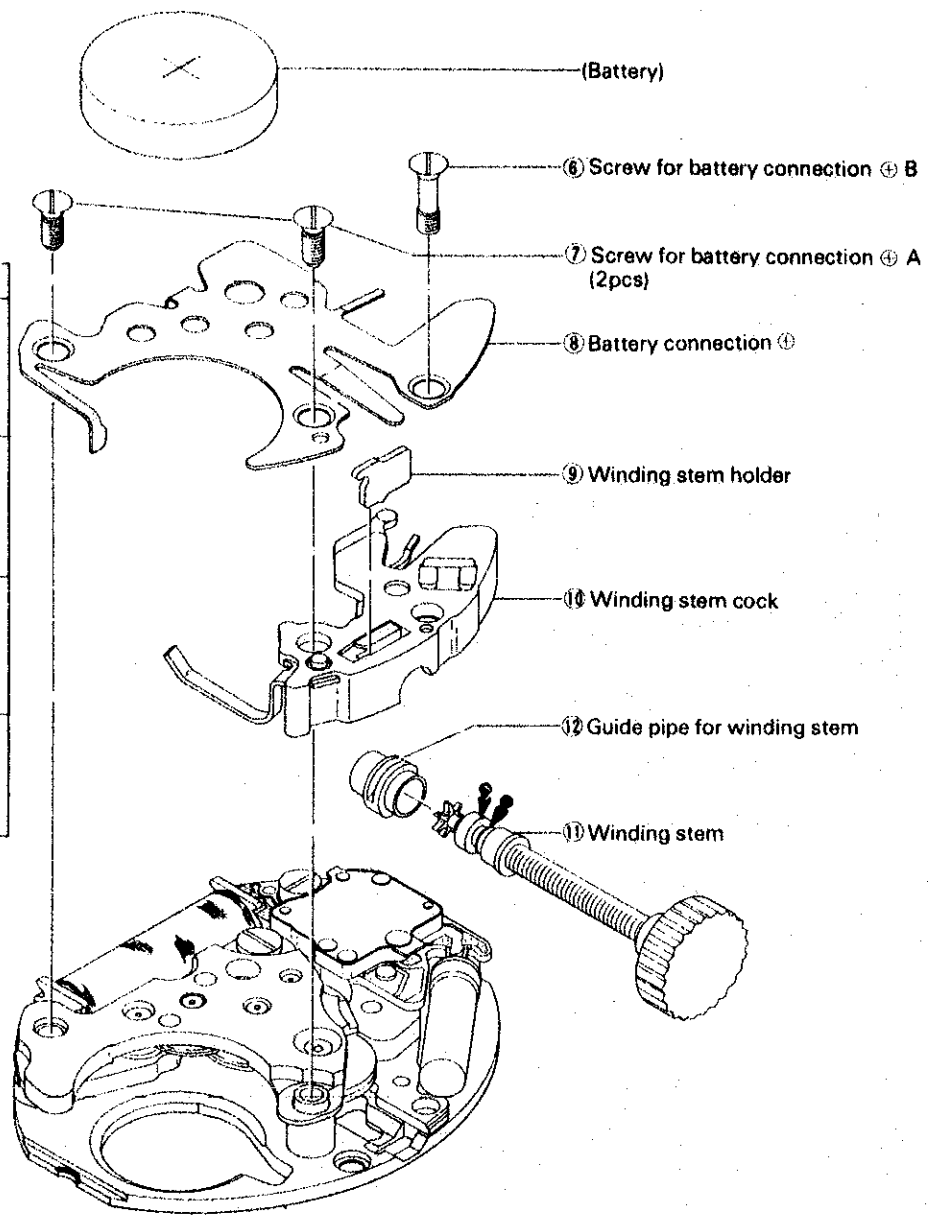

2 Guide pipe for winding stem

Install the guide pipe for winding stem so that the grooved side is positioned outwards. The two flat surfaces could be positioned in the groove in the main plate as shown in the illustrations.

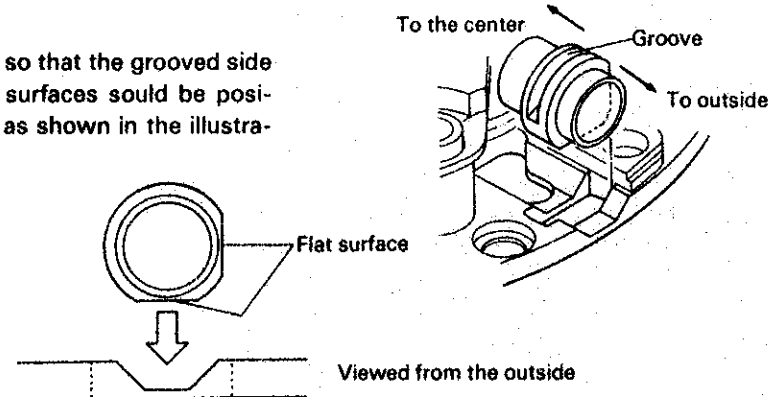

● Train wheel bridge screw ~ main plate

Gear train bridge assembling diagram
Cross-sectional view

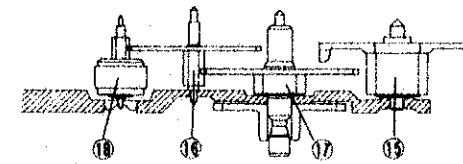

Plan figure

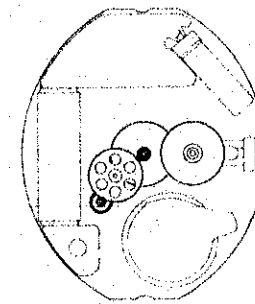

19 Reset pin
To install the reset pin, move the reset lever in the direction of the arrow.

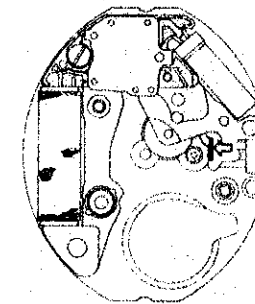

26 Set position of reset lever

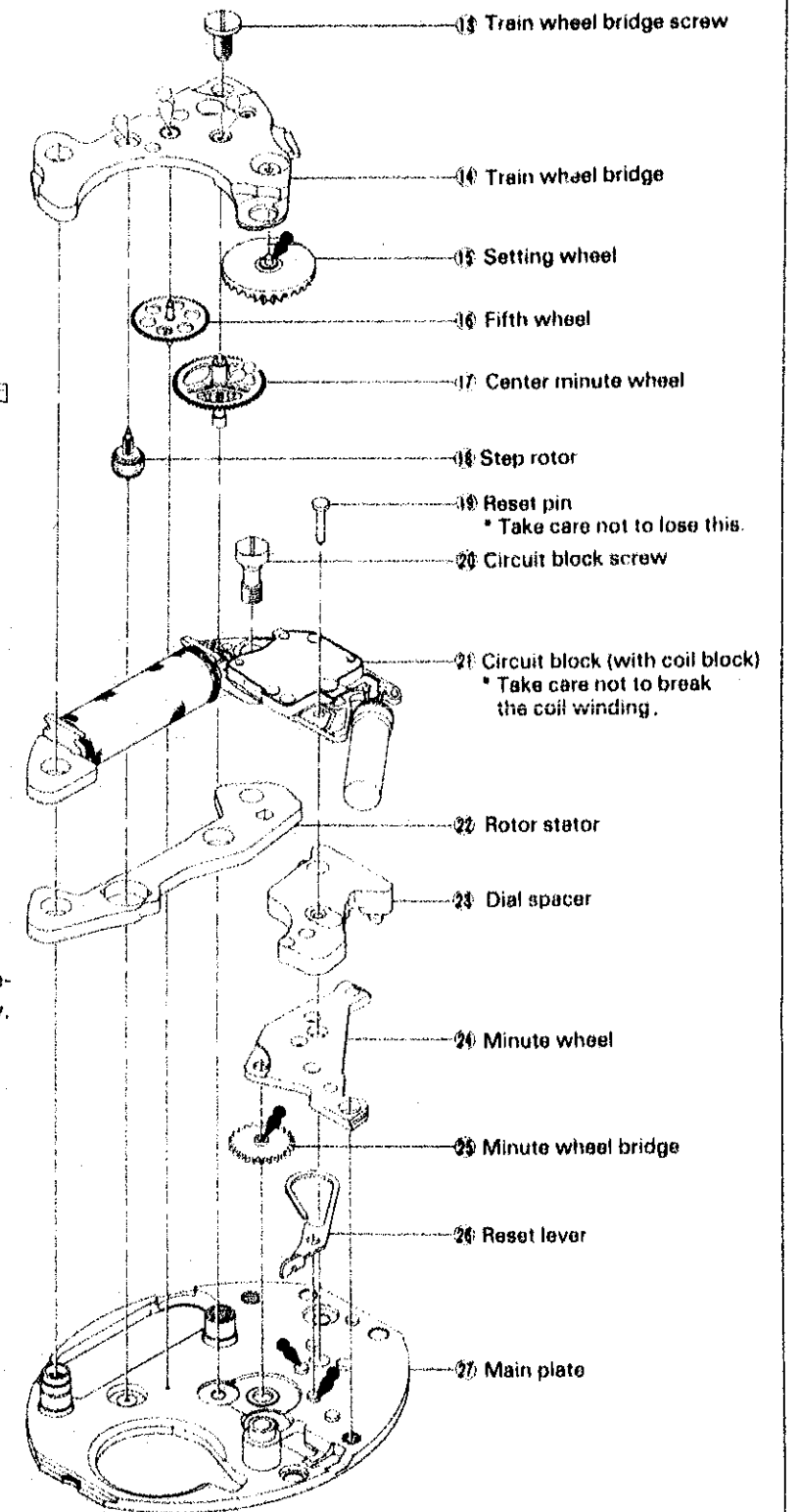
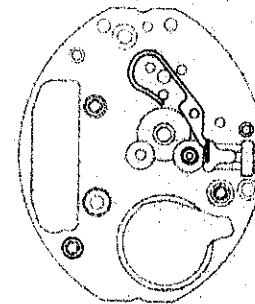

III. CHECKING AND ADJUSTMENT

1 Structure of circuit block

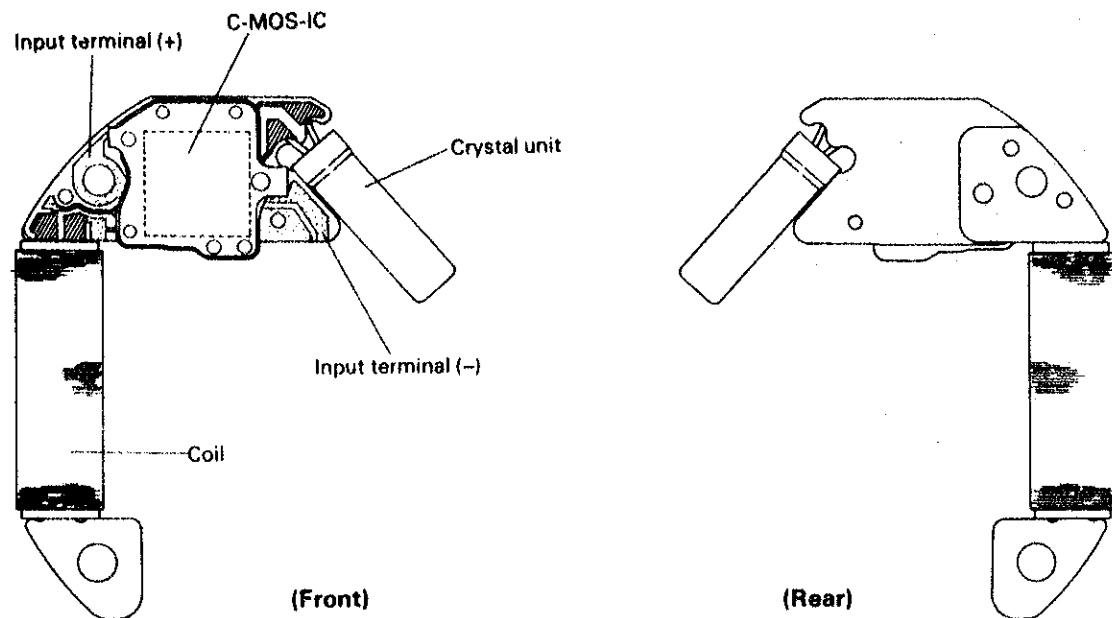

2 Procedure for checking and adjustment

- This section describes the adjustment and maintenance procedures required for this watch.
- For other adjustment and maintenance, refer to the "TECHNICAL GUIDE GENERAL INSTRUCTION, Analogue Quartz"
- The page numbers in this section correspond to those in the "TECHNICAL GUIDE GENERAL INSTRUCTION, Analogue Quartz"

A OUTPUT SIGNAL p.6	
<ul style="list-style-type: none"> ● Check the output signal with the crown in the normal position. 	Output signal → Normal No output signal → Defective Check the battery voltage. * If the battery voltage is normal, replace circuit block.
B BATTERY VOLTAGE p.7	
Range to be used: DC 3V	1.5V or more → Normal Less than 1.5V → Defective * Replace the battery
C BATTERY CONDUCTIVITY p.9	
Check to see if the battery current flow to the circuit is normal.	
D CIRCUIT BLOCK CONDUCTIVITY p.9	
Check for short circuit and defective conductivity of the conductive portions of the circuit block.	

E FRONT GEAR TRAIN MECHANISM p.11

Check the front gear train mechanism for play of wheels and rotors, mis-installation, dust, lint, foreign matter and lubrication.

F REAR GEAR TRAIN MECHANISM p.11

Check the rear gear train mechanism for lubrication, play dust and lint.

G RESET CONDITION p.11

- With the movement assembled, check that the reset condition is normal.
- * For checking, use a quartz tester.
 - 1 Check output signal with the crown set to the normal position.
 - 2 Check output signal with the crown set to the first click position.

Output signal → Normal
 No output signal → Defective

No output signal → Normal
 Output signal → Defective
 Replace the reset lever

H CURRENT CONSUMPTION

1. Range to be used: DC 12 μ A

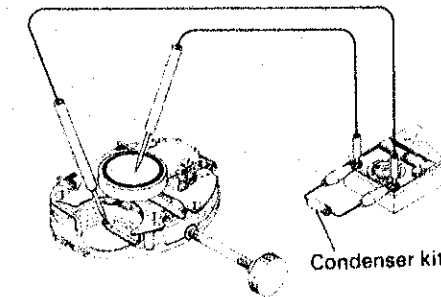

When measuring the current consumption under the incandescent lamp, cover the movement with black cloth. Otherwise the measured value sometimes becomes higher than the actual value.

Less than 0.6 μ A → Normal
 More than 0.6 μ A → Defective
 Proceed to 2.

- As this watch uses 20-second hand movement system, the volt-ohm-meter reads low value when the current is only supplied to the IC. Motor driving current which moves the hand is added to the current supplied to the IC every 20 seconds. At this time, the volt-ohm-meter pointer moves largely.
- The current consumption can be obtained as follows.

EX. IC current = 0.25 μ A
 IC current + motor driving current = 1.10 μ A
 The motor driving current alone is 0.85 μ A. To obtain the current consumption into per second, this value should be converted. When 0.85 μ A is divided by 20, the current consumption necessary only for motor driving is about 0.04 μ A. Therefore, the current consumption is, 0.25 μ A + 0.04 μ A = 0.29 μ A.
- 2. Pull the crown to the first click position and check the current consumption.

Less than 0.5 μ A → Circuit block is normal.
 Check gear train mechanism.
 More than 0.5 μ A → Circuit block is defective.
 Replace the circuit block.

ACCURACY p.13

Use the Quartz Tester with the electromagnetic microphone to check accuracy.

Monthly rate:
 Less than 20 seconds → Normal
 More than 20 seconds → Defective

WATER-RESISTANT QUALITY p.15**APPEARANCE AND FUNCTIONING p.15****IV. PARTS LIST for cal. V230A**

PART NO.	PART NAME
125 231	Train wheel bridge
197 231	Winding stem cock
238 231	Guide pipe for winding stem
261 231	Minute wheel
* 270 231	Center minute wheel
* 270 232	Center minute wheel
* 271 231	Hour wheel
* 271 232	Hour wheel
281 231	Setting wheel
* 354 230	Winding stem
* 354 231	Winding stem
387 231	Minute wheel bridge
491 122	Dial washer
493 130	Hour wheel ring
493 131	Hour wheel ring
493 132	Hour wheel ring
701 231	Fifth wheel
736 231	Winding stem holder
4000 231	Circuit block
4146 231	Step rotor
4225 230	Battery clamp
4239 231	Rotor stator
* 4271 233	Battery connection ⊕
4408 232	Dial spacer
4455 231	Reset lever
011 334	Upper hole jewel for step rotor
011 334	Lower hole jewel for step rotor
012 010	Battery clamp screw
012 495	Train wheel bridge screw
012 496	Circuit block screw
012 818	Screw for battery connection ⊕ A
012 819	Screw for battery connection ⊕ B
017 591	Reset pin
017 662	Tube for train wheel bridge A
017 663	Tube for train wheel bridge B
017 664	Tube for train wheel bridge C
SEIZAIKEN TR521SW	Battery

Remarks:

- * Center minute wheel, Hour wheel
 There are two different types as specified below.
 Combination:

Type	Center minute wheel	Hour wheel
a	270 231	271 231
b	270 232	271 232

- * Winding stem
 The type of winding stem is determined based on the design of case.
- * Battery connection (+) for Pulsar watches
 4271232 (Pulsar marking)