

ISADIGIT

Cal 9012 / 7000

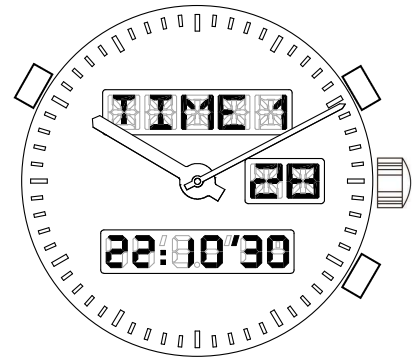

14 ''
31.8 mm
H. 6.20



SYNCHRONIZED ANADIGIT



Voyager



Dual Time



Alarm



Date



1/100 Sec.
Chrono



Anadigit
compass



EL Back Light

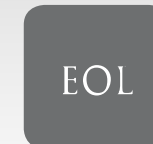

End Of Life

isaswiss

WATCH MECHANISMS

In conformity with RoHS standard

Doc. n° 0312219 - B Up date . 08/03/2011 - Page 1

Caractéristiques :

Mouvement à quartz anadigit multifonctions, 2 aiguilles indépendantes à 2 sens de rotation. LCD positif ou négatif. Affichage analogique des heures et minutes synchronisé sur l'affichage digital.

Affichage digital :

- Mode boussole anadigital.
- Chrono 100 heures (1/100 sec. la 1^{ère} heure).
- Date.
- Bip horaire.
- Calendrier perpétuel 50 ans (depuis le 1^{er} janvier 2000).
- Mode 12 h. / 24 h.
- 2^{ème} fuseau horaire avec permutation possible sur affichage analogique.
- Signal de fin de vie de pile. EOL.
- Alarme.
- Dégageant visuel de l'afficheur.

Tige 2 positions avec poussoir ; 3 poussoirs.
Rétroéclairage EL.

Characteristics :

Multi-function anadigit quartz movement, 2 independent hands in 2 directions drive. Positive or negative LCD.

Analogical display : hours and minutes synchronized on the digital display.

Digital display :

- Anadigit Compass mode
- Chrono 100 hours (1/100 sec. the 1st. hour).
- Date
- Horary chime.
- 50 years perpetual calendar (from Jan 1st. , 2000).
- 12 / 24 hour mode.
- 2nd time zones with permutation on analogical display.
- End of battery life signal. EOL.
- Alarm.
- Visual clearing of the display in setup mode.

Stem 2 positions with push-piece action ; 3 push-pieces.
EL back light.

Kennzeichnungen :

Multifonctionen anadigitales Quarz Uhrwerk, 2 unabhängige Zeiger mit Rotation 2 Richtungen. Positives oder negatives LCD. Anadigitalanzeige : Stunden und Minuten, auf dem digitalen Anschlag synchronisiert.

Digitalanzeige :

- Kompass.
- Chrono 100 Stunden (1/100 Sek. erste Stunde).
- Datum.
- Uhersignalton.
- Kalender vom 01/01/2000 bis 31/12/2049.
- 12 / 24 Stunden Mode.
- 2^{te} Zeitzone mit Umstellung auf Digitalanzeige.
- EOL. Anzeige der Batterie.
- Alarm.
- Visuelle Entlastung der Anzeige im Setup-modus.

Stellwelle 2 Positionen mit Drückeraktion ; 3 Drücker.
EL Rückbeleuchtung.

| Critères/ Criteria/Kriterium | Conditions/Bedingungen | Min. | Typ. | Max. | Unités/Units/Einheit |
|--|------------------------|----------------|----------------|-----------------|--|
| Consommation - Current consumption Stromaufnahme | U= 3 V T=25°C | | 3.20 | | µA |
| Marche instantanée - Instantaneous rate Momentaner Gang | U= 3 V T=25°C | - 0.5 (-15) | | + 0.5 (+ 15) | s/jour s/day s/Tag (s/mois s/month s/ Monat) |
| Température de fonctionnement Operating temperature Betriebstemperatur | | 0 | | + 50 | °C |
| Résistance aux champs magnétiques Resistance to magnetic fields Magnetfelddabschirmung | | | 1500 (18.8) | | A/m (Oe) |

| Qté Qty Menge | Désignation Designation Bezeichnung | Type Model Typ | Tension Voltage Spannung | Code Code Kode | Capacité Capacity Kapazität | Autonomie théorique Theoretical Autonomy Theoretische Gangreserve |
|---------------------|---|----------------------|--------------------------------|----------------------|-----------------------------------|---|
| 1 | Pile Battery Batterie 20.00 x 1.60 | CR 2016 | 3.00 V | | 90 mAh | 39 mois 29* months Monate |

*Avec mode boussole, rétroéclairage et alarme 20 sec. /j - * With compass mode, back light and alarm 20 sec. /d. - *Mit Kompass, Rückbeleuchtung und Alarm 20 Sek. /T.

CAGE / FRAME

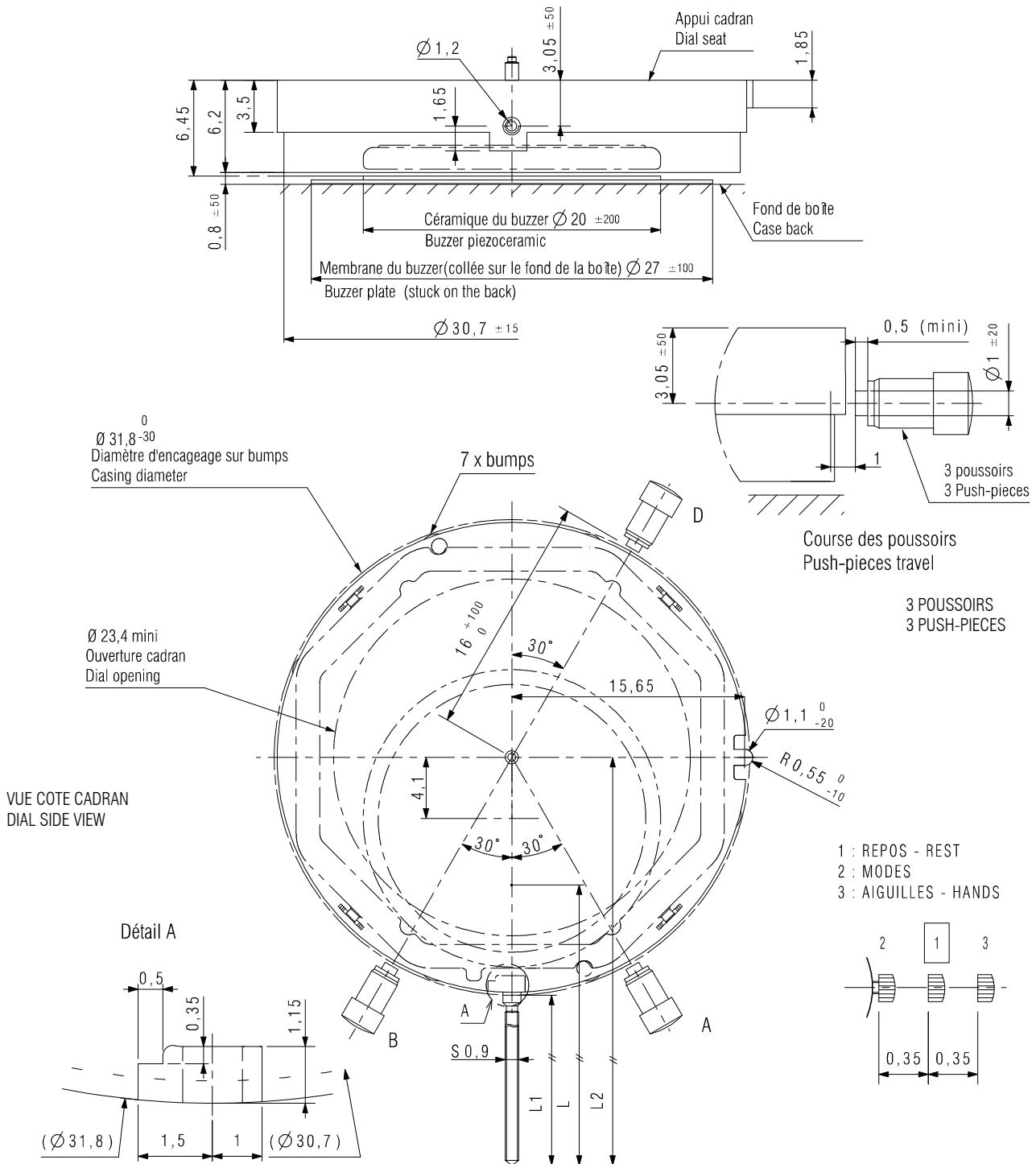

DIMENSIONS IN mm. - TOLERANCES IN µm.

| Tige en position repos / Stem in rest position | L | L1 | L2 |
|--|-----------|-------|------|
| Standard / Standard | 19 +/-100 | 16.30 | 32.2 |

EMBOITAGE ET FIXATION DU MOUVEMENT STANDARDS STANDARD CASING AND MOVEMENT FASTENING

ATTENTION ! Utiliser des matériaux non ferromagnétiques pour la carrure, le cercle d'emboîtement, le fond de boîte et le cadran.
TAKE CARE ! Use non-ferromagnetic materials for the complete case, the casing ring, the case back and the dial.

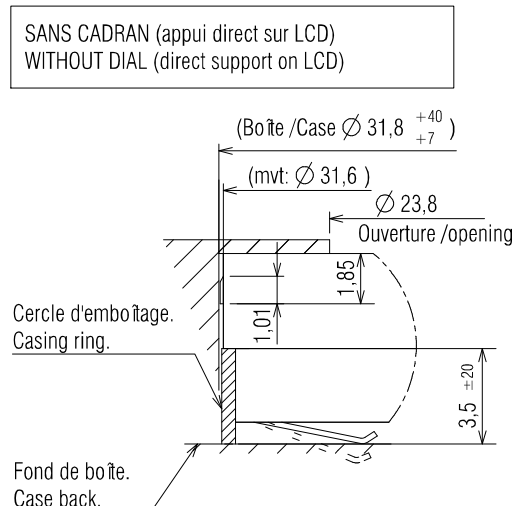
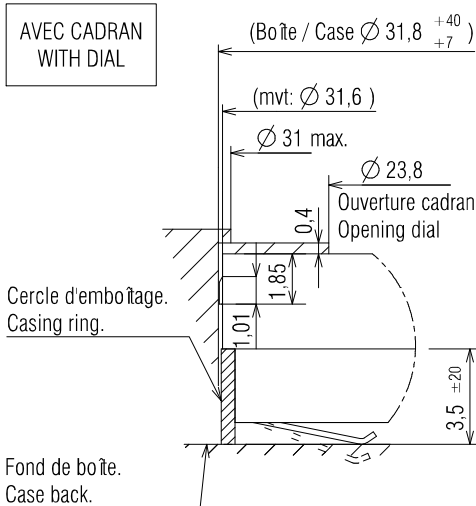

Attention ! Le fond de la boîte doit être très propre.
Take care ! The case back has to be very clean.

CERCLE D'EMBOITAGE EN METAL METAL CASING RING

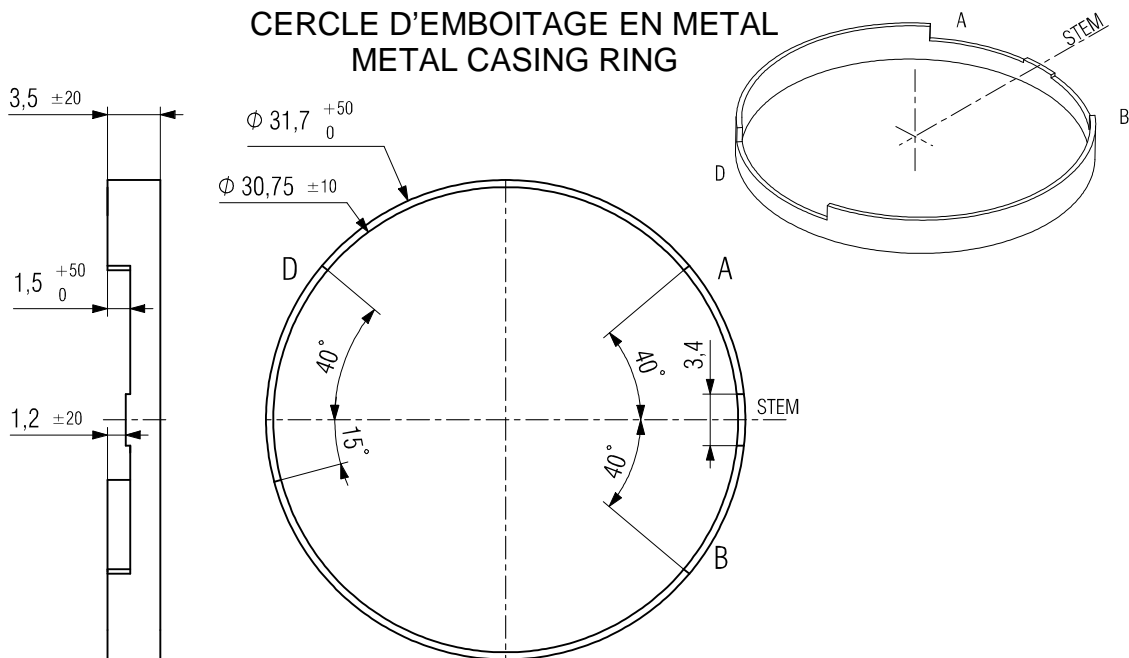

Pour tout autre type d'emboîtement, merci de contacter nos services techniques.
For any other kind of casing, thank you to contact our technical office.

DIMENSIONS IN mm. - TOLERANCES IN μ m.

CADRAN ANNULAIRE / RING DIAL

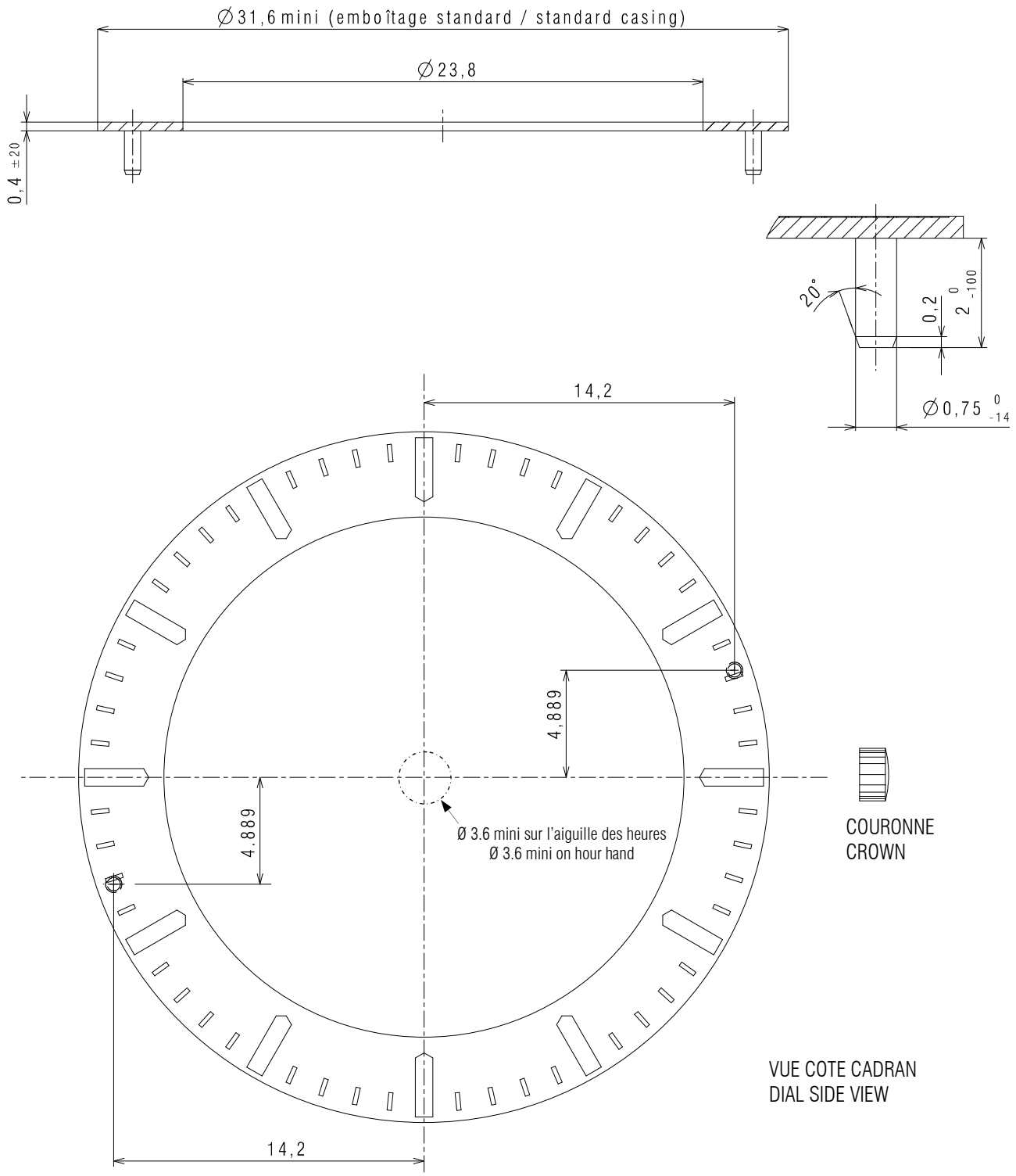

DIMENSIONS IN mm. - TOLERANCES IN μm

In conformity with RoHS standard

Doc. n° 0312219 - B Up date . 08/03/2011 - Page 5

CADRAN PLEIN / FULL DIAL

Ø 31.6 mini (emboîtement standard / standard casing)

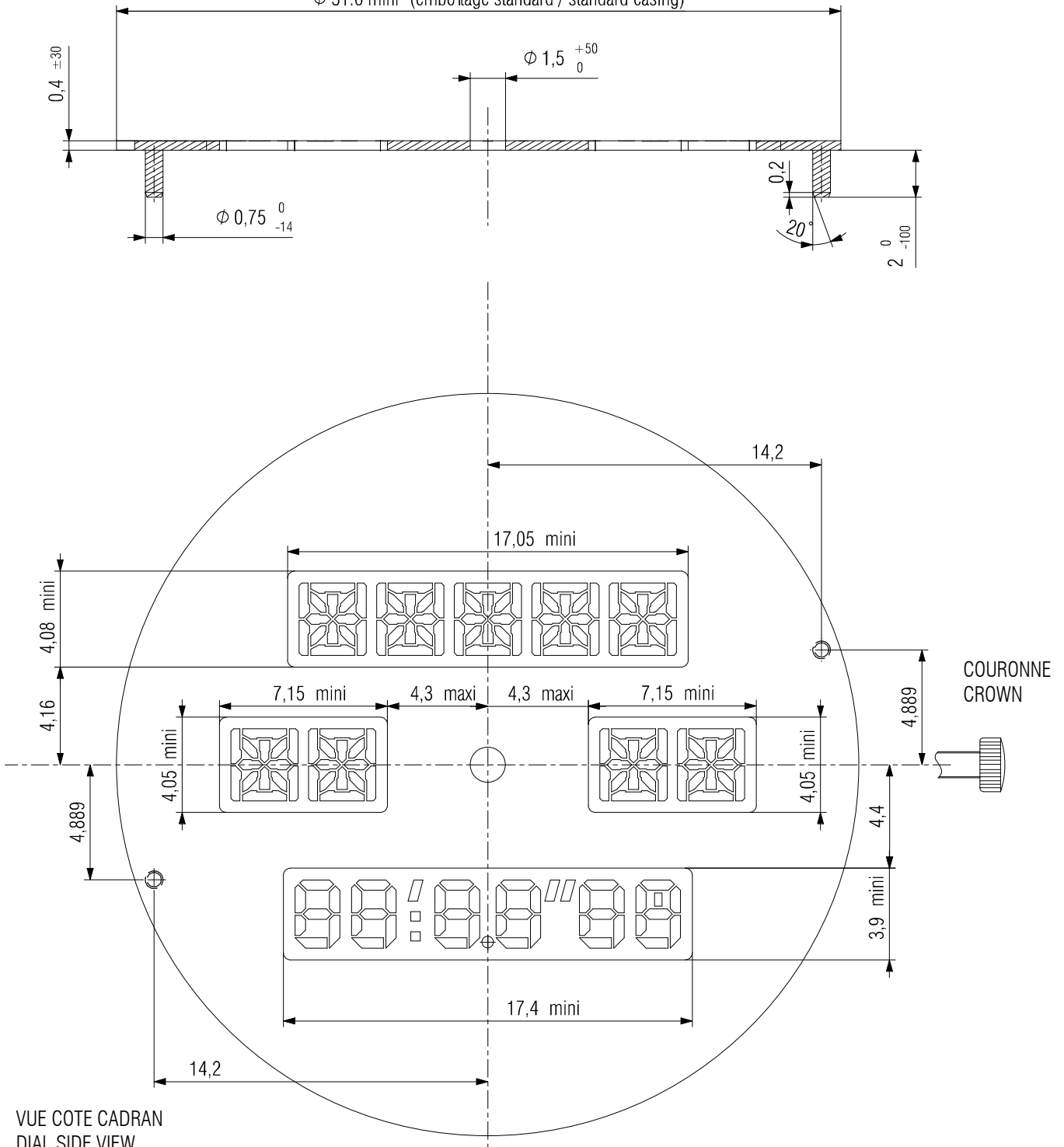

VUE COTE CADRAN
DIAL SIDE VIEW

DIMENSIONS IN mm. - TOLERANCES IN µm

In conformity with RoHS standard

Doc. n° 0312219 - B Up date . 08/03/2011 - Page 6

AIGUILLAGES / HAND-FITTING

**AUTRES AIGUILLAGES SUR DEMANDE
OTHER HAND-FITTING ON REQUEST**

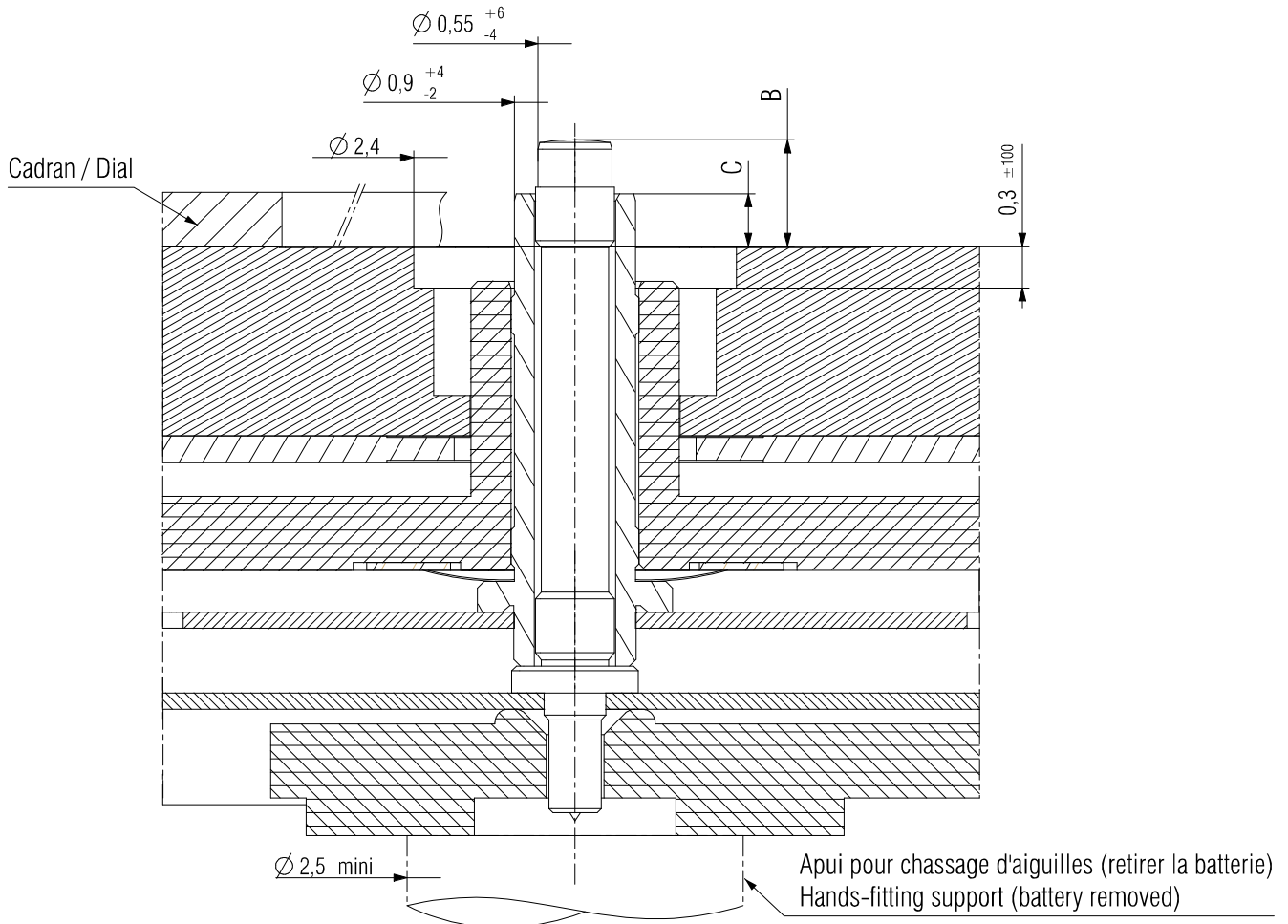

DIMENSIONS IN mm. - TOLERANCES IN µm.

| AIGUILLAGE / HAND-FITTING | Dépassement / Height over dial seat | | Epaisseur cadran / Dial Thickness |
|---|-------------------------------------|------------------------------|---|
| | B | C | |
| | Chaussée / Cannon pinion | Roue des heures / Hour wheel | |
| N°1 avec Cadran annulaire/ N°1 with ring dial | 0.80 | 0.40 | - |
| N°2 avec Cadran annulaire ou cadran plein / N°2 with ring dial or full dial | 1.20 | 0.80 | 0.40 maxi. |
| N°4 avec Cadran annulaire ou cadran plein / N°4 with ring dial or full dial | 1.60 | 1.20 | 0.80 maxi. |
| Hauteur canon aig. / Hand pipe height | 0.35 | 0.40 | - |
| CHOCS 450 g / 450 g SHOCKS | Masse / Mass | Balourd / Unbalance | FORCE DE CHASSAGE / PRESS-IN-FORCE |
| Aiguille des minutes - Minute Hand | ≤ 30 mg | ≤ 1.2 µNm | 10N à/to 20 N |

In conformity with RoHS standard

Doc. n° 0312219 - B Up date . 08/03/2011 - Page 7

ISADIGIT

9012/ 7000

 SWISS MADE

14'''
31.8 mm

EXEMPLE DE PRESENTATION
DESIGN SAMPLE



DIMENSIONS IN mm. - TOLERANCES IN μ m.

In conformity with RoHS standard

Doc. n° 0312219 - B Up date . 08/03/2011 - Page 8

ISASWISS
WATCH MECHANISMS

www.isaswiss.com

ISA SWISS S.A.
Champ-Nauger 2
CH -2416 Les Brenets
Switzerland
Tél +41 (0)32 930 80 85
Fax +41 (0)32 930 80 86

ISA PACIFIC Co. Ltd.
Room 1605, Eastern Center
1065 King's Road, Quarry Bay,
Hong-Kong
Tél +852 21 68 33 88
Fax +852 25 18 30 33

DIRECTIVES POUR LA REALISATION DU FOND DE BOITE CASE BACK MANUFACTURING INSTRUCTIONS

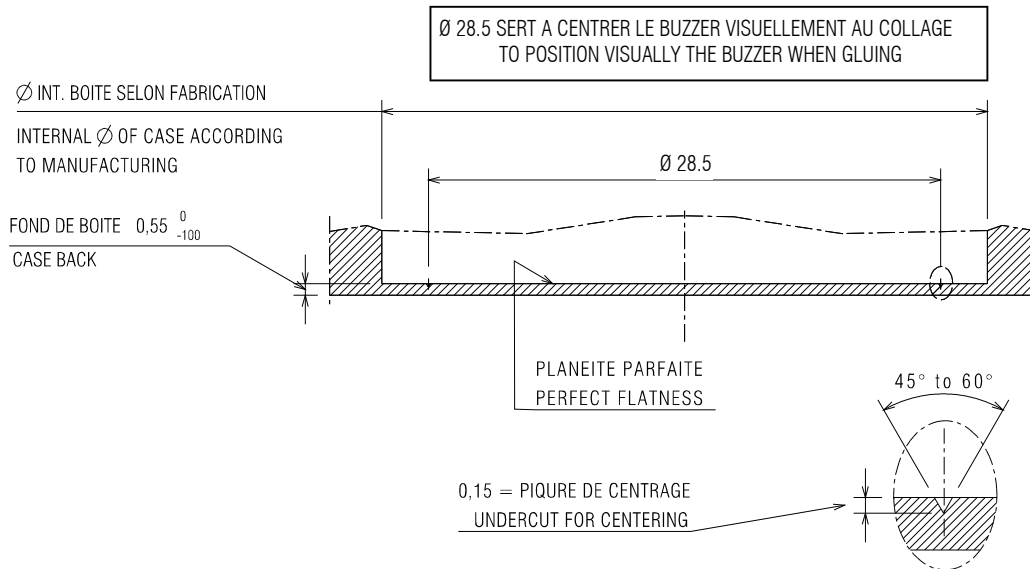

INSTRUCTIONS POUR LE COLLAGE DU BUZZER BUZZER GLUING INSTRUCTIONS

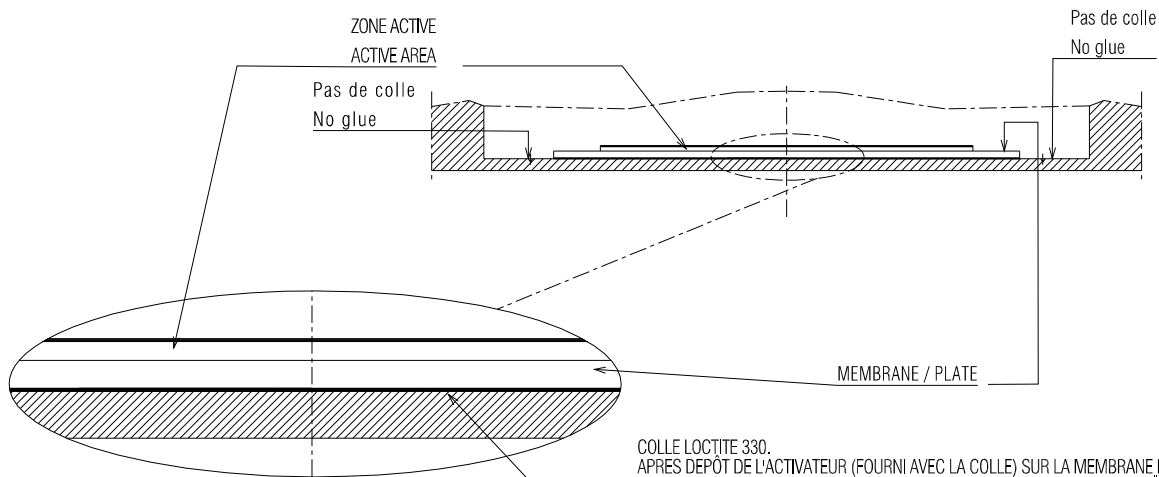

COLLE LOCTITE 330.
APRES DEPOT DE L'ACTIVATEUR (FOURNI AVEC LA COLLE) SUR LA MEMBRANE DU VIBREUR, DEPOSER REGULIEREMENT UN FILET DE COLLE SUR LE FOND DE BOITE : POSITIONNER LE VIBREUR, PUIS LE MAINTENIR EN PLACE SOUS UNE CHARGE DE 2,5N. (250gf.) PENDANT UNE DUREE DE 30 MINUTES.
L'UTILISATION DE LA COLLE NE DOIT PAS ETRE FAITE DANS L'ENVIRONNEMENT PROCHE DES MOUVEMENTS POUR EVITER LES PROBLEMES DE TRANSFORMATION DES LUBRIFIANTS PAR SUITE DE DEGAZAGE.

LOCTITE 330 GLUE
AFTER THE DEPOSIT OF THE ACTIVATOR (GIVEN WITH THE GLUE) ON THE PLATE OF THE BUZZER, DEPOSIT REGULARLY A GLUE FILET ON THE CASE BACK : SET THE BUZZER IN THE RIGHT POSITION AND MAINTAIN IT IMMEDIATELY UNDER A PRESSURE OF 2,5N. (250gf.) AT LEAST 30 MINUTES.
REMARKS : THE GLUING OPERATION SHOULD NOT BE DONE CLOSE TO THE MOVEMENTS TO AVOID THE IMPORTANT RISK OF LUBRICANT TRANSFORMATION DUE TO THE GLUE OUTGASING.

DIMENSIONS IN mm. - TOLERANCES IN µm.