

***TECHNICAL
INFORMATION***

**CITIZEN QUARTZ
Cal.No. 912※※**

1. OUTLINE



This watch features the calendar display of "year", "month", "date" and "day" in addition to the normal time display of "hour", "minute", "second", "AM/PM", "date" and "day". At the same time, the time display can be selected freely in either a 24-hour period or a 12-hour period. Furthermore, the watch incorporates various kinds of additional mechanisms such as the built-in internal illumination lamp, forced returning device, automatic calendar correcting device, and others. With these multiple functions plus an excellent handling performance and an attractive thin and compact design, the watch will meet well the requirements of users in every generation.



Movement
(Power cell side)

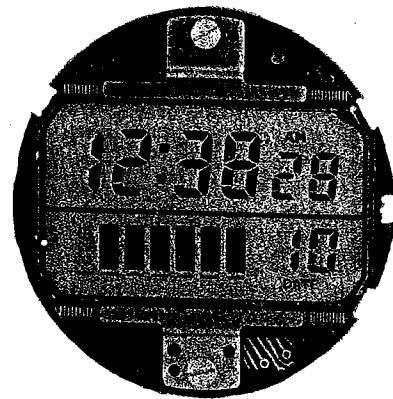

Movement
(LC display panel side)

2. FEATURES

1) Free selection between 24-hour and 12-hour period display

In accordance with the daily life of each individual, the time display can be selected freely between a 24-hour period and a 12-hour period through one-touch operation of the push-button.

2) Time screen of multiple display

The time display of "hour", "minute", "second", "AM/PM", "date" and "day" are constantly displayed. And the time display can be changed to the calendar display of "year", "month", "date" and "day" through a switching operation.

3) Automatic calendar correction

The "year", "month" and "date" are all memorized in a C/MOS-LSI. Accordingly, the calendar is corrected and set automatically at the end of each month if the year is once set.

4) Compact and thin structure

The movement measures only 5mm thick, although a number of functions are contained in it.

5) Built-in illumination lamp

An illumination lamp built in the watch facilitates an easy and clear time readout even in the dark.

6) Smooth manipulation ensured by switching mechanism of push-button type

The display switch, display correction and watch internal illumination can easily be performed through operation of three kinds of push-buttons.

7) Easy disassembly and assembly:

Thanks to much reduction of the component parts, the disassembly and assembly become very simple.

8) Uninterrupted operation for about two years by a small-size silver oxide power cell:

The reduction of power consumption at the electronic circuit makes it possible to operate the watch accurately for about two years with a small-size silver oxide power cell.

3. HANDLING INSTRUCTIONS
CAL. NO. 9120A

1) HOW TO SELECT 12-HOUR/24-HOUR PERIOD DISPLAY

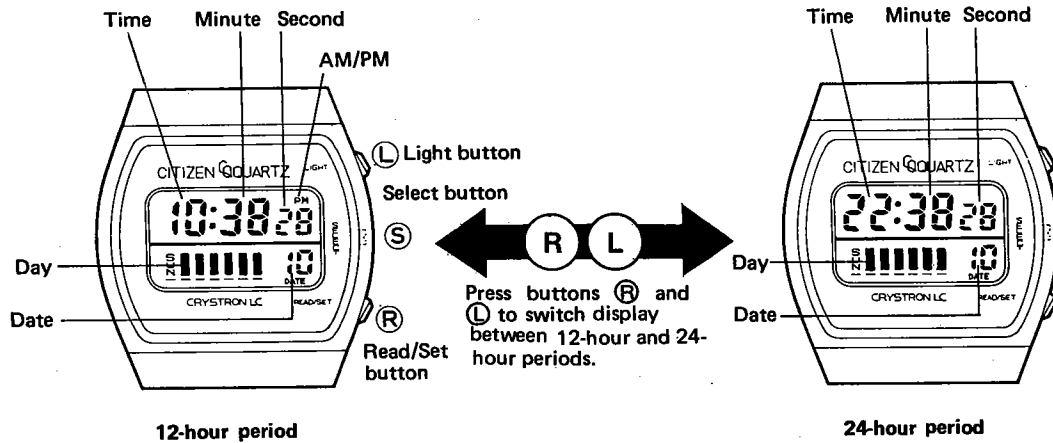

2) HOW TO READ TIME AND CALENDAR

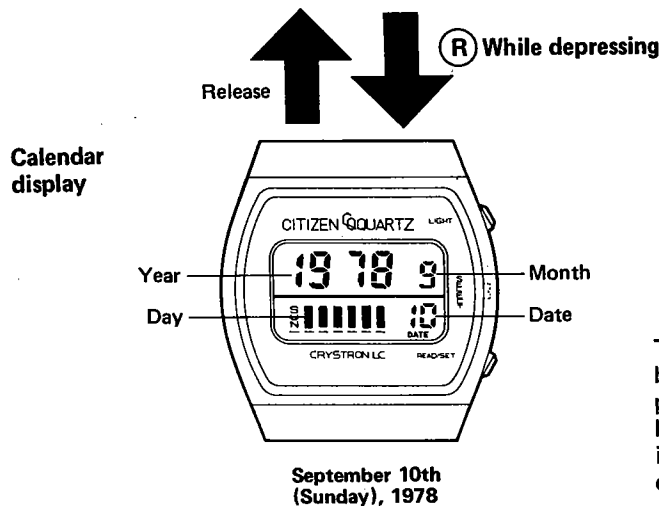
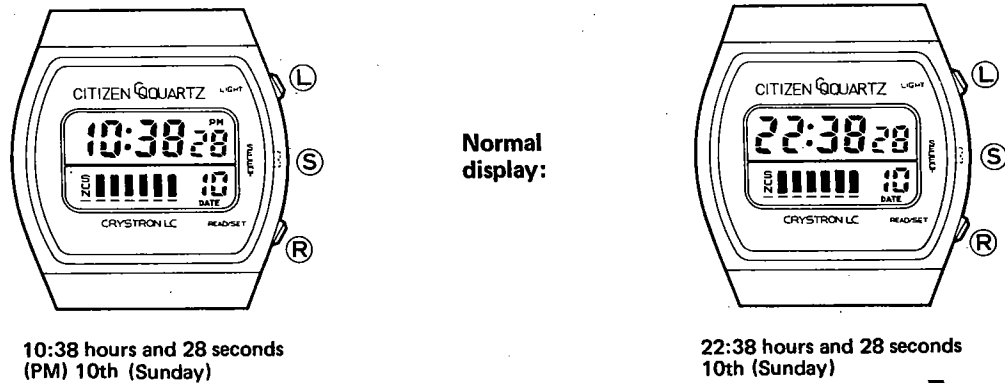

The calendar display is possible while (R) button is being pressed. With release of (R) button, the calendar display is changed to the normal time display.

3) HOW TO SET TIME AND CALENDAR

Either a 24-hour or 12-hour period display is possible, and here the description is given based on the 12-hour period.

When button **L** is pressed, the time indication will return to normal display, regardless of the watch setting.

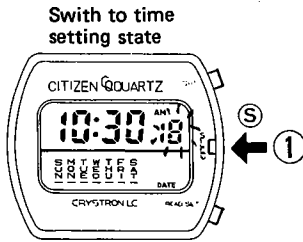

- ① "Second" starts to flicker immediately upon pressing the **S** button (day and date are turned off). The **S** button has been made flush with the body so that it must not be inadvertently pressed. To press, use a sharp instrument such as a ball-point pen, etc.

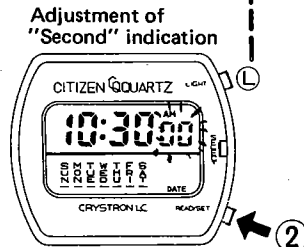

- ② Press button **R** simultaneously with the time signal. The "Second" indication will show 00. The "Minute" indication will advance when the "Second" indication is between 30 to 59 seconds.

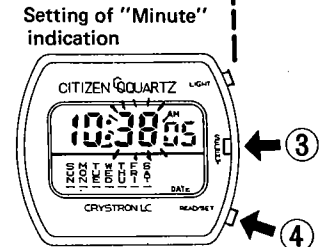

- ③ The "Minute" indication will start to flicker when this button is pressed.
- ④ The "Minute" indication will advance every time this button is pressed. Adjust minutes with this button.

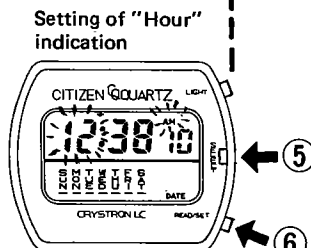

- ⑤ "Hour" and "AM/PM" indications will start to flicker when this button is pressed (note that "AM/PM" is not provided in the case of 24-hour period display).
- ⑥ "Hour" indication will advance every time this button is pressed. Adjust "Hour" with this button. Make sure "AM/PM" when adopting 12-hour period display.

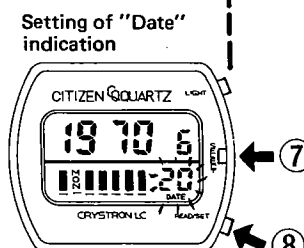

- ⑦ "Date" starts to flicker as soon as this button is pressed.
- ⑧ Adjust "Date" with this button.

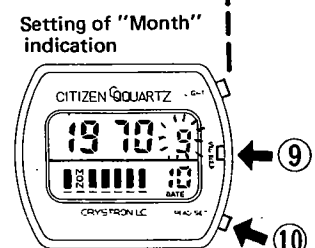

- ⑨ "Month" indication starts to flicker as soon as this button is pressed.
- ⑩ Adjust "Month" with this button.

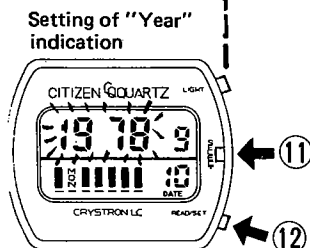

- ⑪ "Year" indication starts to flicker as soon as this button is pressed.
- ⑫ Adjust "Year" with this button (when button is pressed, the year indication will be returned from year 2009 to 1970).

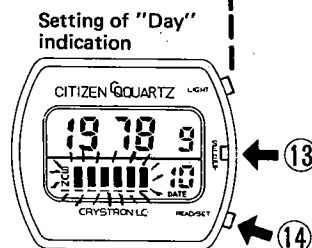

- ⑬ "Day" indication starts to flicker as soon as this button is pressed.
- ⑭ Adjust "Day" with this button.

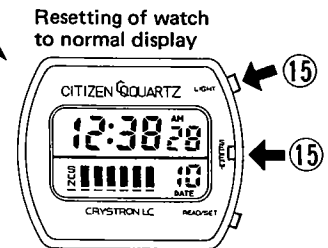

- ⑮ Press this button to reset the watch to normal display. This setting can also be done with **S** or **L** button.

CAL. NO. 9121A

1) HOW TO READ TIME AND CALENDAR

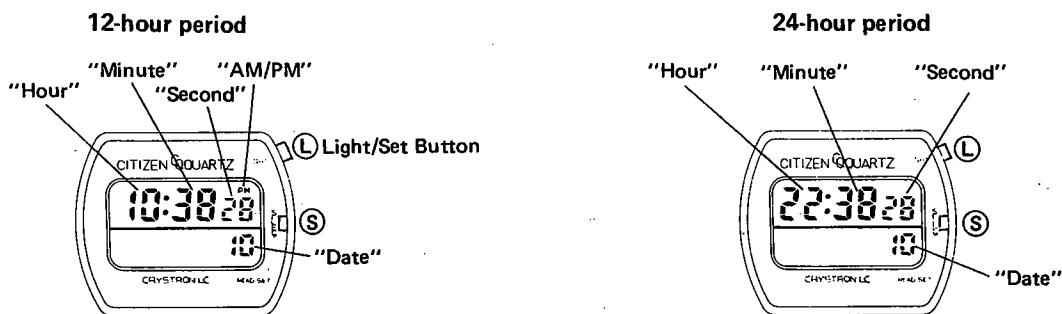

(Either a 12-hour or 24-hour period display can be selected at the display correction time)

2) HOW TO SET TIME AND CALENDAR

Switch to time setting state

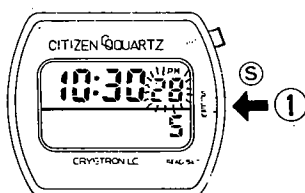

① "Second" Starts to flicker immediately upon pressing the S button (date is turned off). The button has been made flush with the body so that it must not be inadvertently pressed. To press, use a sharp instrument, such as a ball-point pen, etc.

Adjustment of "Second" indication

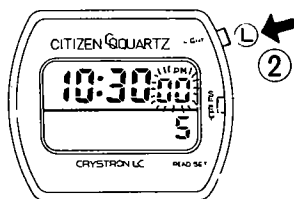

② Press button L simultaneously with the time signal. The "Second" indication will show 00. The "Minute" indication will advance when the "Second" indication is between 30 to 59 seconds.

Setting of "Minute" indication

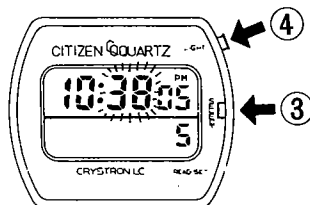

③ The "Minute" indication will start to flicker when this button is pressed.
④ The "Minute" indication will advance every time this button is pressed. Adjust minutes with this button.

Setting of "Hour" indication

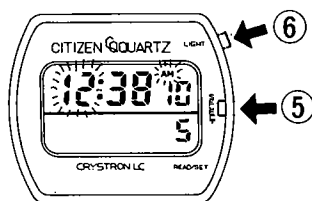

⑤ "Hour" and AM/PM indications will start to flicker when this button is pressed (note that AM/PM is not provided in the case of 24-hour period display).
⑥ "Hour" indication will advance every time this button is pressed. Adjust "Hour" with this button. (Make sure AM/PM when adopting 12-hour period display.)

Setting of "Date" indication

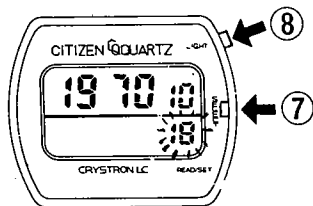

- ⑦ "Date" starts to flicker as soon as this button is pressed.
- ⑧ Adjust "Date" with this button.

Setting of "Month" indication

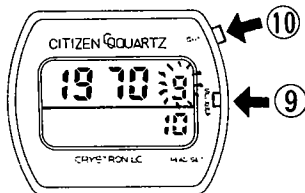

- ⑨ "Month" indication starts to flicker as soon as this button is pressed.
- ⑩ Adjust "Month" with this button.

Setting of "Year" indication

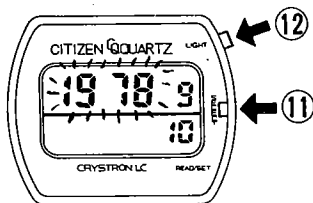

- ⑪ "Year" indication start to flicker as soon as this button is pressed.
- ⑫ Adjust "Year" with this button (when button is pressed, the year indication will be returned from year 2009 to 1970).

Holding

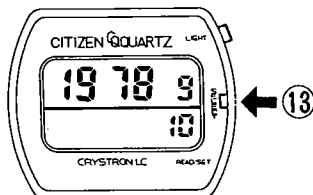

- ⑬ The indication will be held when "Year" is adjusted and the flickering will stop.

Switching between 12-hour and 24-hour period displays

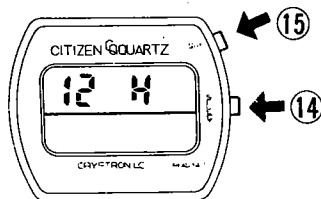

- ⑭ 12-hour or 24-hour period display can be set by pressing this button.
- ⑮ Either 12-hour or 24-hour period display is given when this button is pressed.

Resetting of watch to normal display

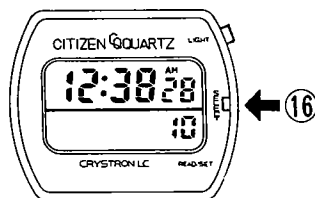

- ⑯ Press this button to reset the watch to the normal display.

Notes: 1. Under the normal time display, the lamp lights up with push of (L) button, but does not light up under the display correction state even if (L) button is pushed.
 2. The display correction is carried out in a 24-hour period as far as the 24-hour period display is adopted, and in a 12-hour period as far as the 12-hour period display is selected respectively.

4. STRUCTURE AND FUNCTION

1) Structure

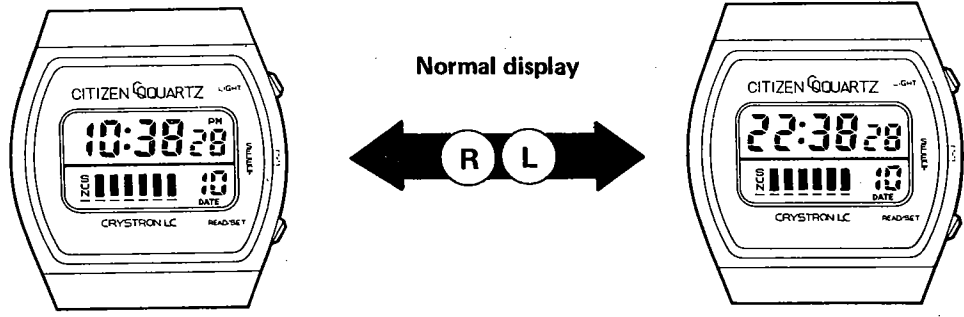
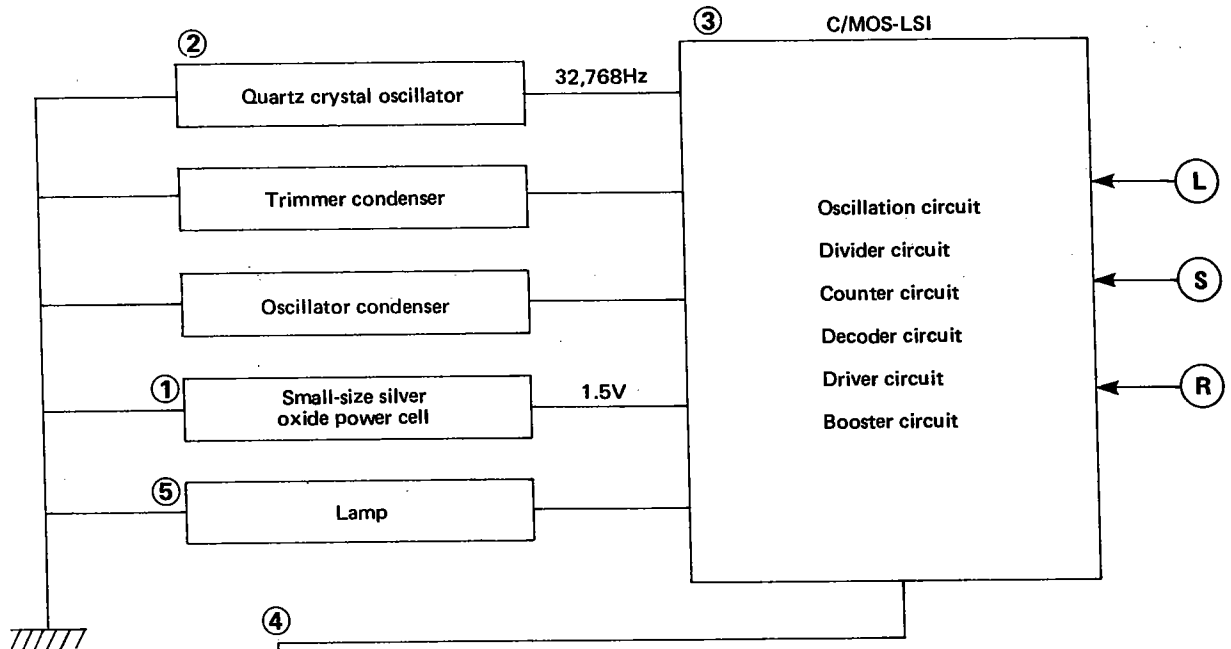

12-hour period 24-hour period
 Select one

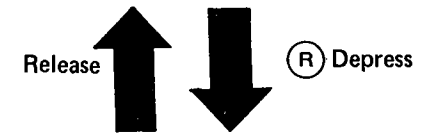

Calendar display

2) Function

The Citizen Quartz Crystron LC Chronograph (Cal. No. 9120A) consists of ① small-size silver oxide power cell, ② quartz crystal oscillator and oscillator circuit, ③ booster/counter/driver circuit, and ④ LC display time screen. Furthermore, it incorporates ⑤ illumination lamp, one of the unique additional mechanisms.

The quartz crystal oscillator provides an extremely high oscillation of 32,768Hz, which will be directly converted into an electrical signal of 32,768Hz. These electrical signals will be divided through the divider circuit down to a necessary frequency. The divided signals will then be counted by the counter circuit according to "normal time", "calendar", "chronograph" and "dual time" respectively.

The counted signals will be sent to the decoder circuit to determine which segment of a display figure should be applied with voltage to. Then these selected signals will be amplified via the driver and booster circuits to finally be supplied to the LC display time screen.

Note: Under 0°C temperature, the whole area of the time screen may sometimes begin to flash. This is the same phenomenon as when the power cell life indicator mechanism operates. In this case, however, if the flashing discontinues by returning the watch to the normal temperature, it is judged that the flashing phenomenon is entirely due to the temperature change and there is no need to replace the power cell. (In case the power cell life comes to end, the flashing will never discountinue even after the watch is returned to the normal temperature.)

5. SPECIFICATIONS

Cal. No.	9120A	9121A
Movement	Diameter: 25.7mm ϕ	
	Thickness: 5.0mm	
Oscillation	32,768Hz	
Accuracy	± 15 sec./month under normal temperature	
Display system	FE twist-type nematic CL display	
Display information	<ul style="list-style-type: none"> ●Normal display 12-hour period: "hour", "minute", "second", "AM/PM" "day" and "date" 24-hour period: "hour", "minute", "second", "day" and "date" ●Calendar display "year", "month", "day" and "date" 	12-hour period: "hour", "minute", "second", "AM/PM" and "date" 24-hour period: "hour", "minute", "second", and "date"
Display correction	Independent correction of each digit by operation of push-button	
Effective temperature range	0°C (32°F) ~ +60°C (140°F)	
Semiconductor	C/MOS-LSI	
Additional mechanisms	<ul style="list-style-type: none"> ●Illumination lamp ●Automatic calendar setting at the end of each year and month 	
Power cell	Small-size silver oxide power cell Parts. No. : 280-15 Voltage : 1.5V Capacity : 60mAH Size : 11.6mm ϕ X 3.0mm Life : About 2 years	

6. DISASSEMBLY AND ASSEMBLY OF MOVEMENT

Disassembling procedure: ① → ⑫
 Assembling procedure : ⑫ → ①
 The number of screws necessary for parts is shown like (T 2)

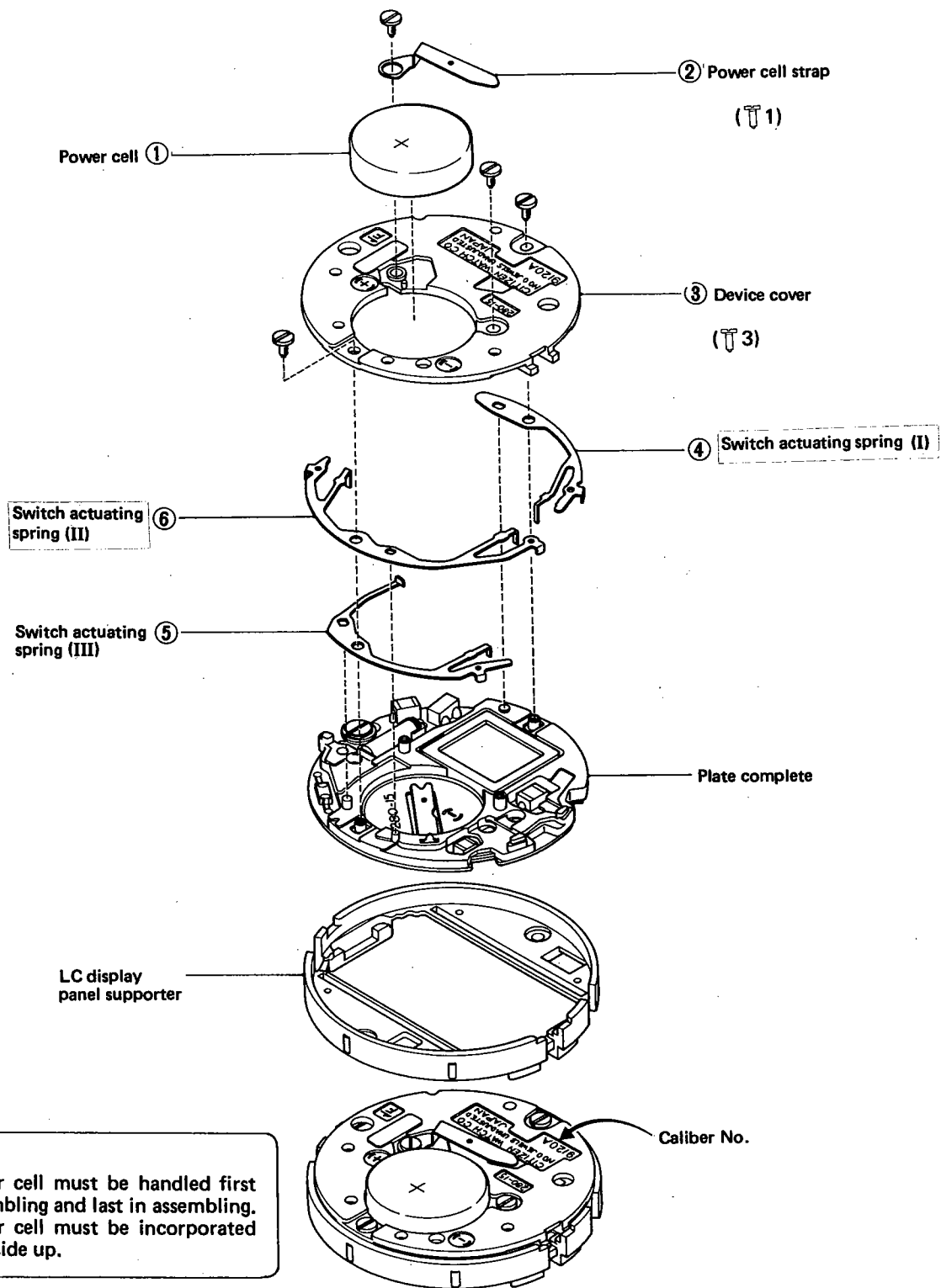

Note:
 The power cell must be handled first in disassembling and last in assembling. The power cell must be incorporated with plus-side up.

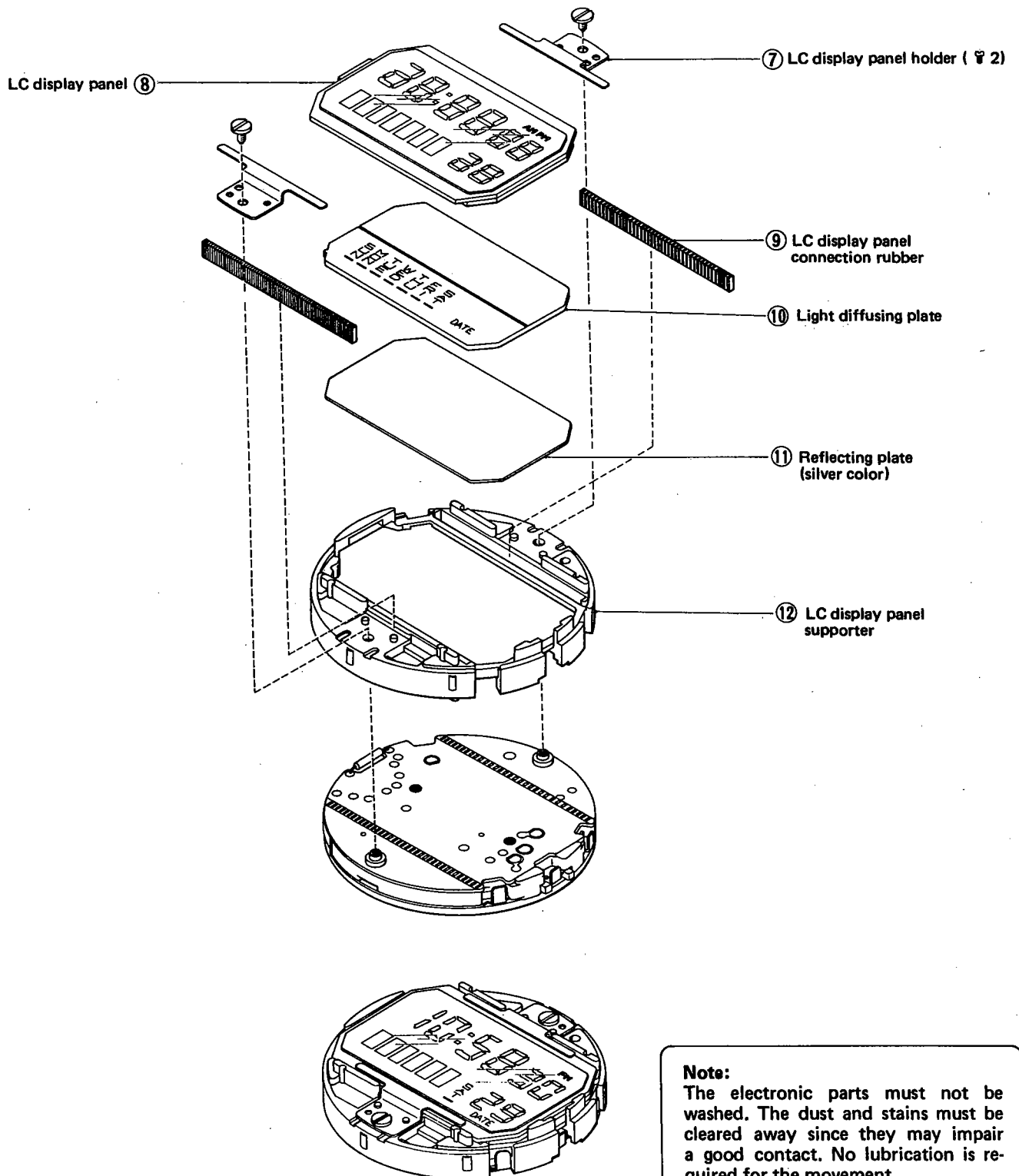

■ Notes

1. Handling of LC display panel:

A deflecting plate is mounted in a unit to both the upper and lower surfaces of the LC display panel. To avoid giving flaws or stains on the deflecting plate, hold the utmost outer circumference of the plate when handling and use the fingerstalls or a bamboo tweezers.

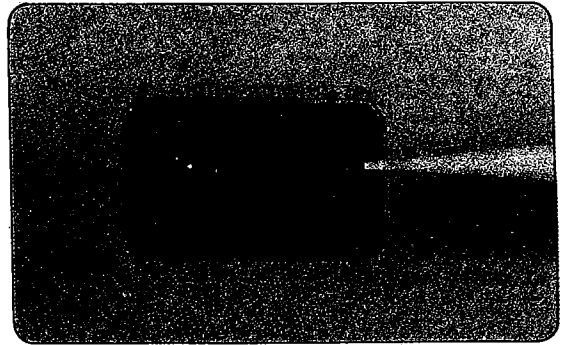

2. Handling of light diffusing plate and reflecting plate:

In order to protect damage or stains, use fingerstalls or bamboo tweezers and hold the extreme edge of the plate when handling both the light diffusing plate and reflecting plate.

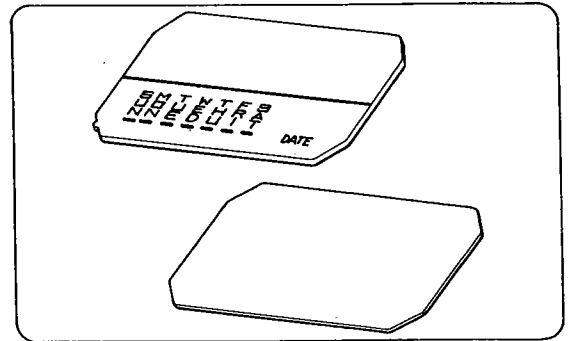

3. The plate of this watch is mode of polyimide mixed with glass:

So that take good care not to cause cracks or flaws on it. Although a special protective treatment is applied on the plate, finger prints or flaws caused by the use of a metal tweezers may deteriorate the plate function. Therefore, use fingerstalls or bamboo tweezers when handling the plate.

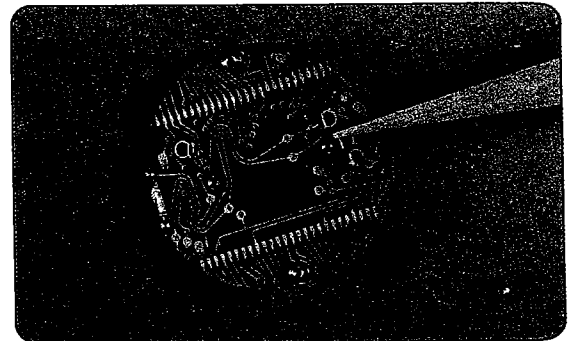

4. Handling of LC display panel connection rubber:

The LC display panel connection rubber functions to perform an electrical conduction between the plate and LC display panel. In this respect, conduct an immediate replacement of the rubber if it loses elasticity or is extremely stretched out to ensure a sufficient contact with the LC display panel supporter.

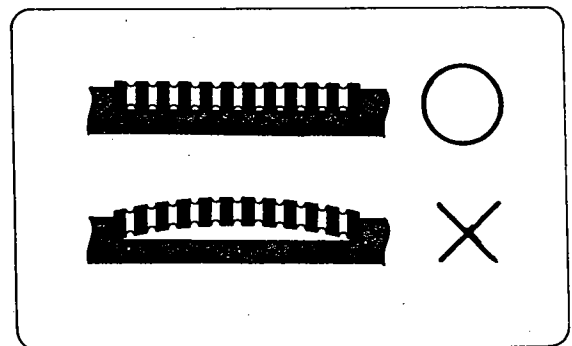

5. Handling of power cell strap:

As shown in the right diagram, the power cell strap is not holding the power cell in a completed state with appearance parts. When measuring the time rate in a state of a single unit state of the movement, the power cell must be fixed by turning the power cell strap as shown in the diagram.

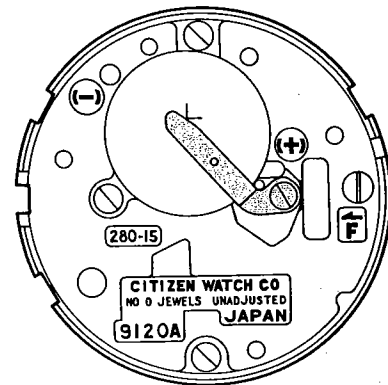
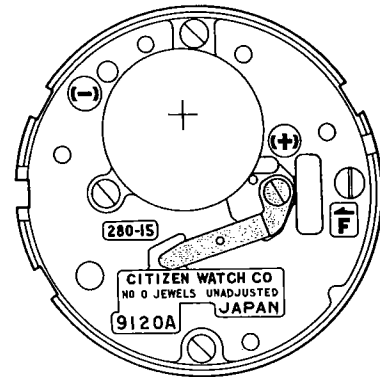

7. TROUBLESHOOTING

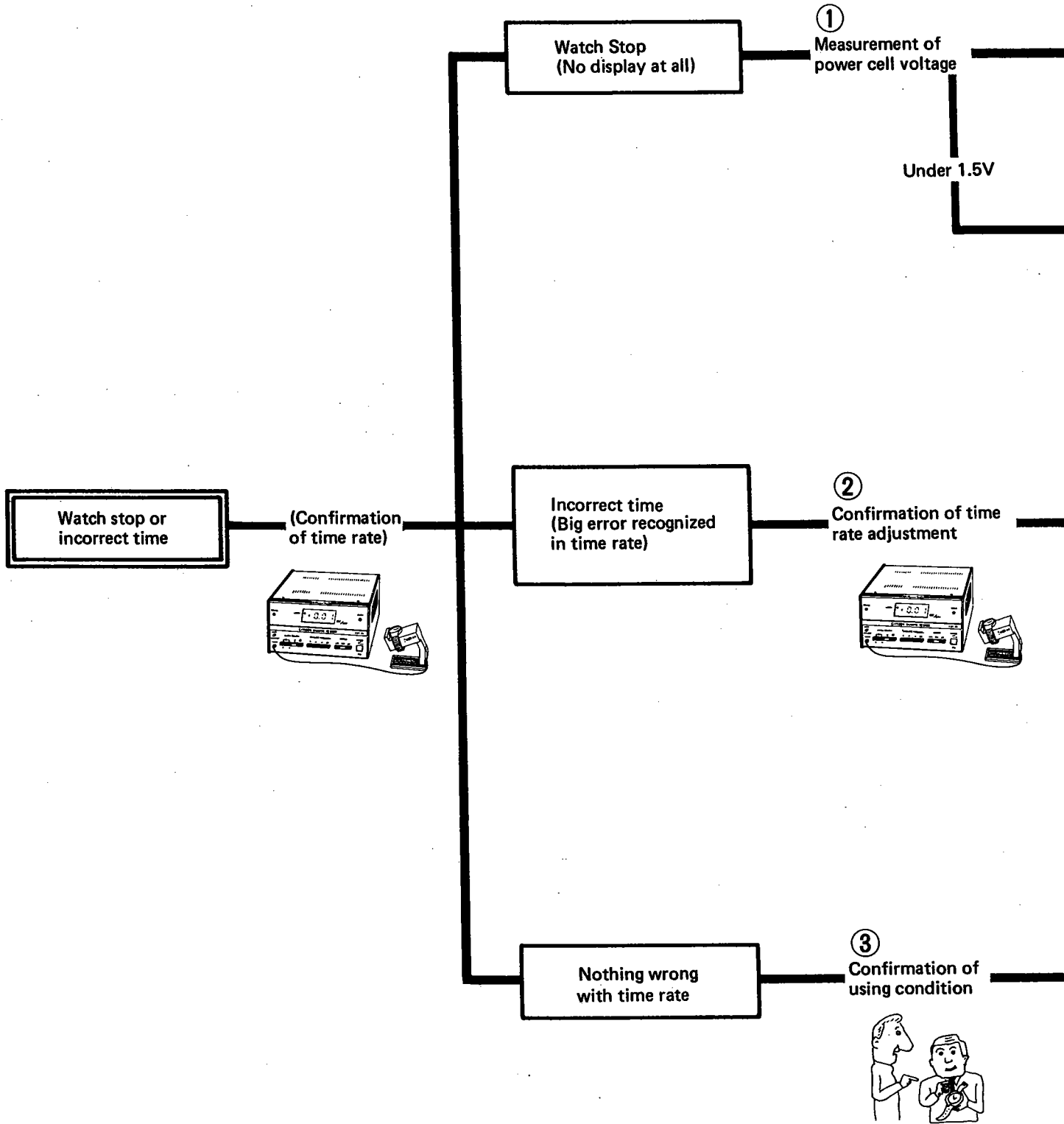

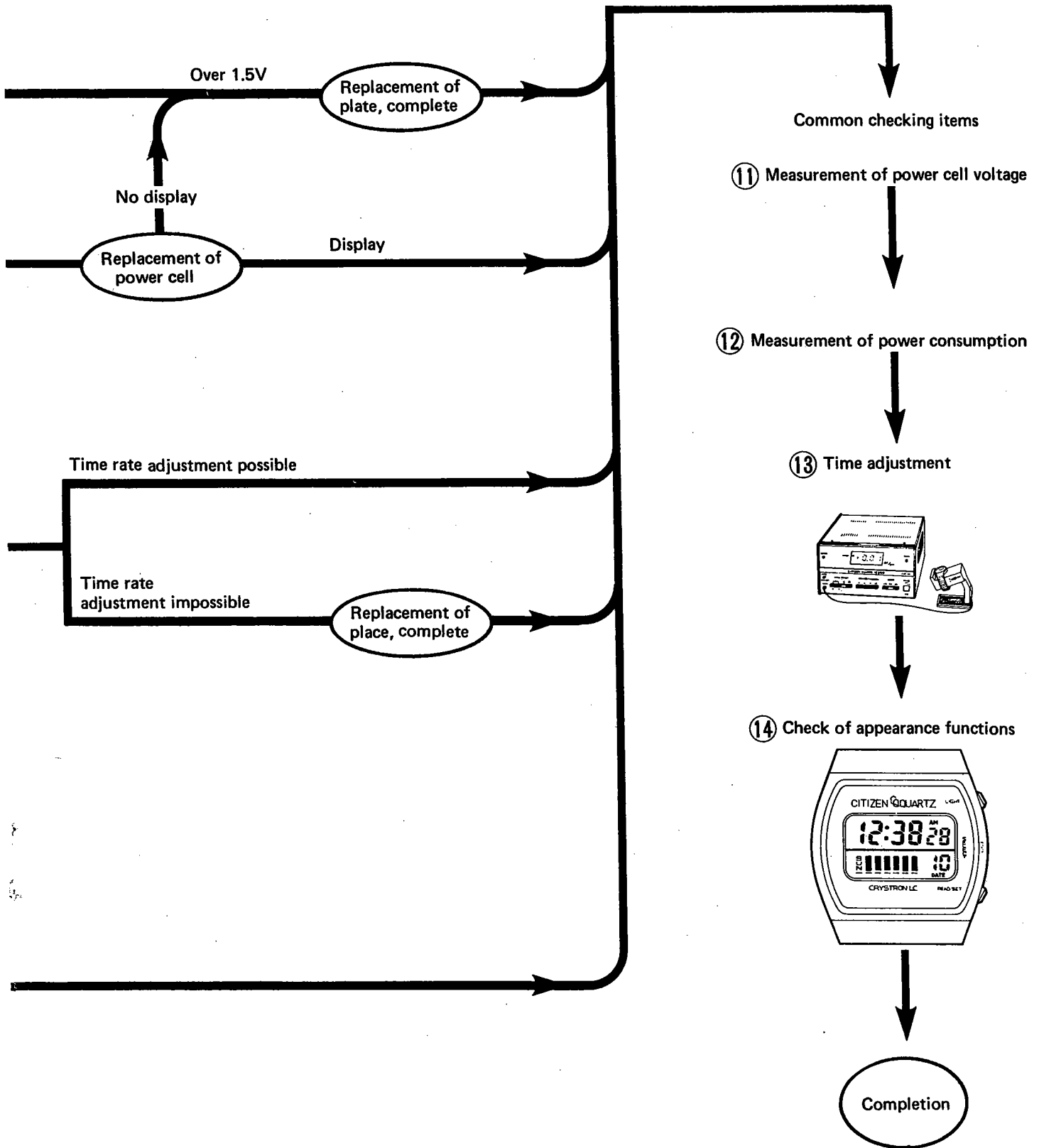

Incomplete functioning of display mechanism

Segment invisible partially



④ Check of display palen connection section

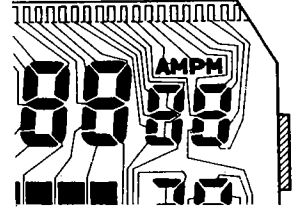

Incomplete functioning of additional mechanisms

Display switching (Normal ⇌ Calendar) impossible

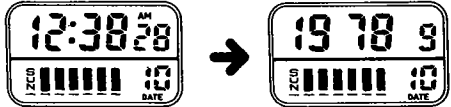

⑤ Check of display switching (Normal ⇌ calenda) mechanism

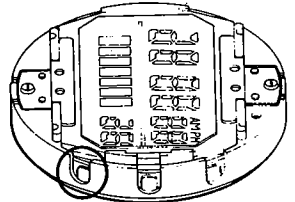

Display switching (12-hour period ⇌ 24-hour period) impossible

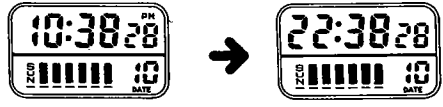

⑥ Check of display switching (12-hour 24-hour period mechanism)

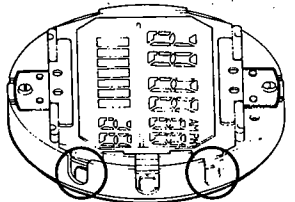

Time digit selection impossible

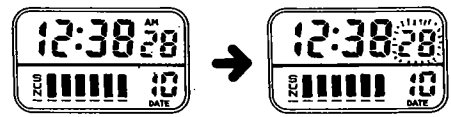

⑦ Check of digit selection mechanism

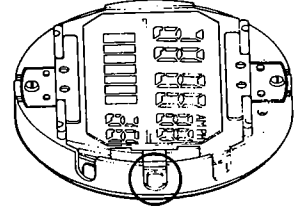

No lamp lighting

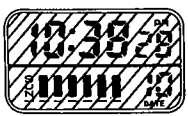

⑧ Check of lamp lighting mechanism

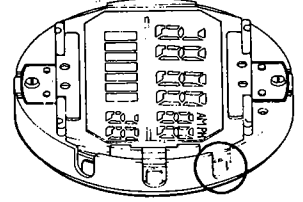

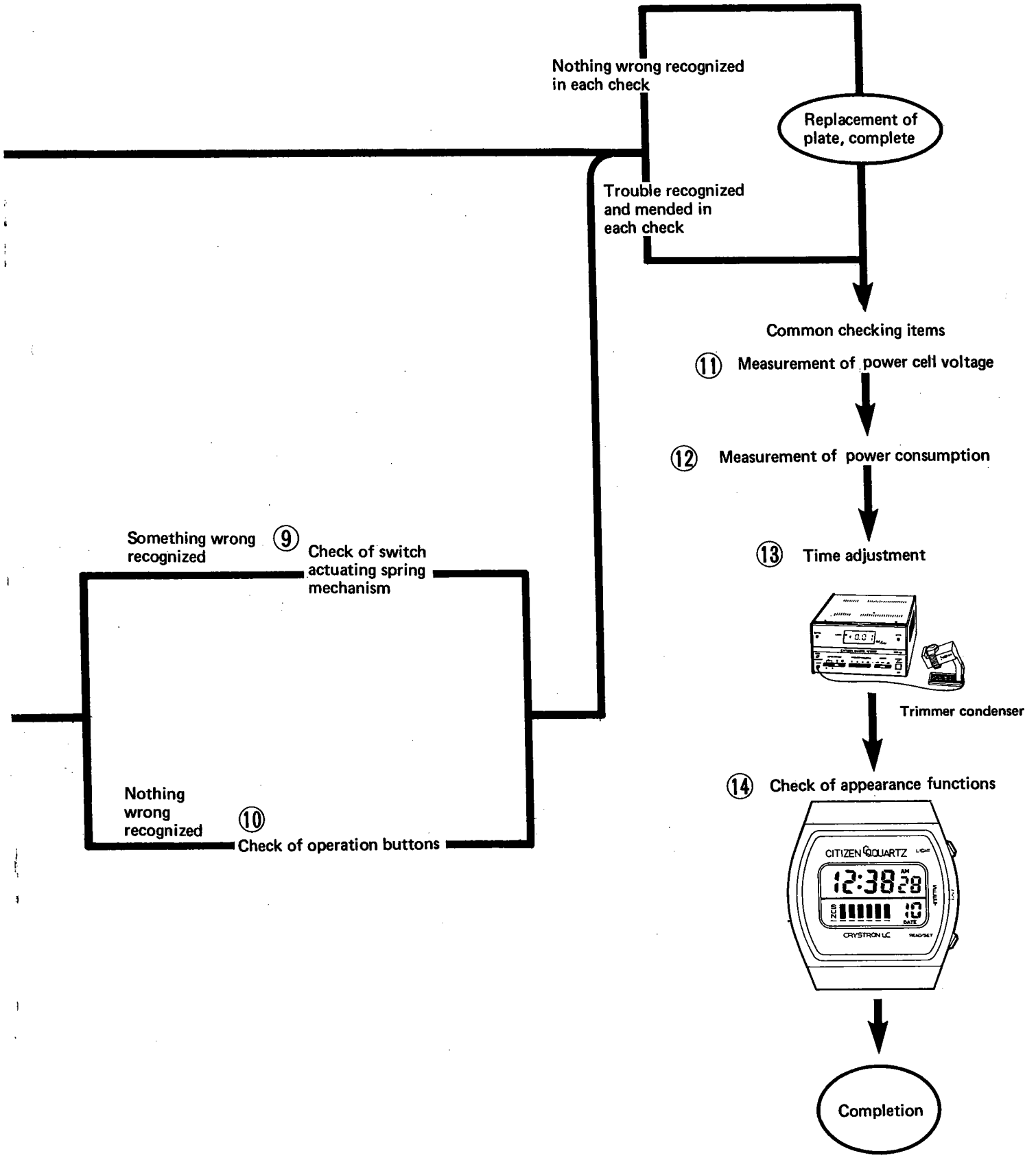

Nothing wrong recognized in each check

Replacement of plate, complete

Trouble recognized and mended in each check

Common checking items

11 Measurement of power cell voltage

12 Measurement of power consumption

13 Time adjustment

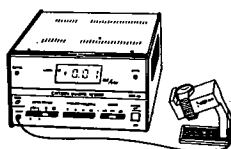

Trimmer condenser

14 Check of appearance functions



Completion

Something wrong recognized

9 Check of switch actuating spring mechanism

Nothing wrong recognized

10 Check of operation buttons

Watch stop – No display at all

1 Measurement of power cell voltage

Power cell voltage: Over 1.5V

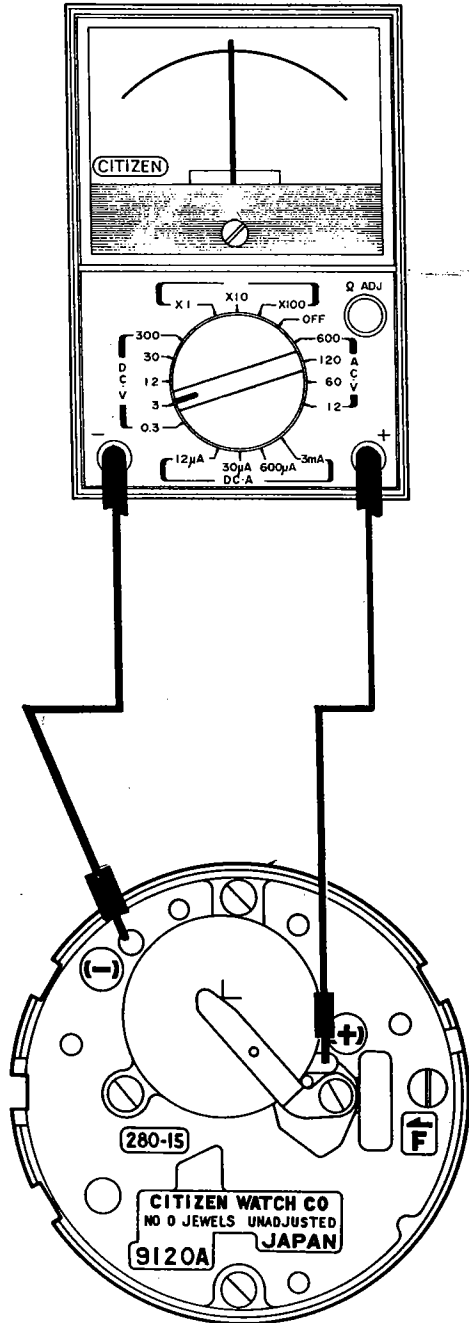

Result and Treatment

Over 1.5V

- Correct display of LC display panel
→ ⑫ Measurement of power consumption
- No display of LC display panel
→ Replace plate.

Under 1.5V

Replace power cell:

- Correct display of LC display panel
→ ⑫ Measurement of power consumption
- No display of LC display panel
→ Replacement of plate, complete

Note

If the watch has been used more than two years, replace the power cell with the new one even if it shows more than 1.5V output power.

How to Install Power Cell

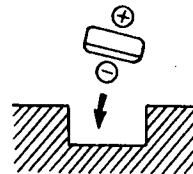

When installing power cell into the watch, make the minus (-) side face down.

Big error recognized in time rate

Check item	How to check	Results	Treatment
<p>2 Confirmation of time rate adjustment</p>	<p>For the cause for incorrect time (big error), it is considered that the quartz crystal oscillator attached to the plate has a big error in its frequency. Conduct check in the following procedure.</p> <p>(1) Check whether the trimmer condenser is capable of adjusting the time or not.</p> <div data-bbox="479 604 860 982" style="text-align: center;"> </div> <p>(2) The trimmer condenser can perform time adjustment.</p> <p>(3) In case the trimmer condenser is unable to adjust time, it is considered that the quartz crystal oscillator is faulty.</p> <p>Check points When a big amount of gain is recognized in the time rate measurement or there is no difference at all in the time rate even if the trimmer condenser is turned right and left, it is considered that the dielectric substance used for trimmer condenser has some cracks. In such a case, replace the plate, complete.</p>		<p>⑪ Measurement of power cell voltage</p> <p>Replacement of plate, complete</p>

Nothing wrong recognized in time rate

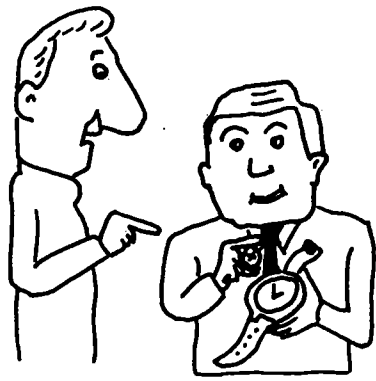
Check item	How to check	Results	Treatment
<p>3 Confirmation of using condition</p>	<p>Check how the customer has used the watch.</p> <p>Ex. Aren't there any mistakes in handling the watch? And other factors.</p> 		

Incomplete functioning of display mechanism – Segment invisible partially

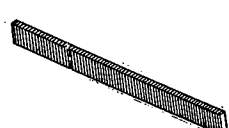
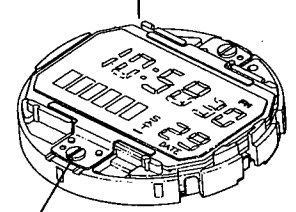
Check item	How to check	Results	Treatment
<p>4 Check of LC display panel connection part</p>	<p>As for the cause of the segment invisible, two factors are conceivable: the contact is unstable between the LC display panel and the electronic circuit; and the electronic circuit has some defects. However, the former may be more in case, so that conduct check placing major emphases on the contact sections.</p> <ol style="list-style-type: none"> 1. Check the screws for LC display panel holder and related condition. <ol style="list-style-type: none"> (1) Aren't there any broken screws? (2) Aren't there any loosened screws? (3) Is the LC display panel holder holding the LC display panel evenly? 2. Check the LC display panel connection rubber for electrical contact. <ol style="list-style-type: none"> (1) Isn't the rubber twisted? (2) Isn't the rubber worn out or extremely stretched out? (3) Aren't dusts or stains attached on the rubber?  <p>LC display panel connection rubber</p>	 <p>Screw for LC display panel holder</p> <p>Screws broken →</p> <p>Screws loosened →</p> <p>LC display panel held unevenly →</p> <p>Rubber twisted →</p> <p>Rubber worn out →</p> <p>Dusts or stains attached →</p>	<p>Replace broken screws and fasten them tight.</p> <p>Tighten them again.</p> <p>Reassembling</p> <p>Replacement of rubber</p> <p>Replacement of rubber</p> <p>Removal</p>

Check item	How to check	Results	Treatment
	<p>3. Referring to the illustration below, check the LC display panel's electrode sections of the segment invisible—whether or not there are any dust or stains stuck.</p> <div data-bbox="495 499 933 882" style="text-align: center;"> </div> <p>Check points The quickest way of checking the segment breakage is to softly press the place around the segment-broken area as illustrated in the picture below. At this moment, if the broken segment is displayed again it is manifest that the cause of the segment disappearance lies in an incomplete contact between the LC display panel and the electronic circuit.</p> <div data-bbox="438 1291 1006 1774" style="text-align: center;"> </div> <p>Note: Well mind not to use a strong force when pressing the LC display panel in order to avoid the glass breakage.</p>	<p>Dust or stains attached →</p> <p>Nothing wrong perceived →</p>	<p>Remove them.</p> <p>Replace LC display panel, even after which trouble is not solved. → Replacement of plate, complete</p>

Display switching (12-hour ⇔ 24-hour indication) impossible

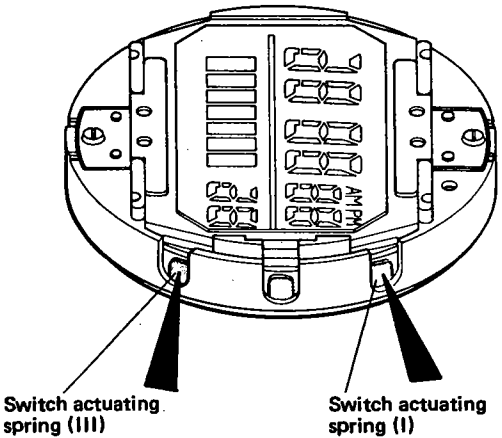
Check item	How to check	Results	Treatment
<p>6 Check of display switching (12 hour ⇔ 24 hour period) mechanism.</p>	<p>In case the switching is impossible between 24-hour and 12-hour period displays under the normal time display, it is conceivable that some fault exists in the electrical factor (trouble in electronic circuit) or in the mechanical factor (unstable contact, deformation or breakage of parts). So have a check for the above factors as follows.</p> <p>Take out the movement from watchcase.</p> <p>Then, push both the switch actuating spring (I) and (III) simultaneously with a tweezers, and confirm that the time display switches properly between the 24-hour and 12-hour periods.</p>  <p>Switch actuating spring (III)</p> <p>Switch actuating spring (I)</p>	<p>Display switching possible</p> <p>Display switching impossible</p>	<p>No trouble with electrical factor → ⑩ Check of operation buttons.</p> <p>⑨ Check of switch actuating spring mechanism</p>

Digit selection impossible

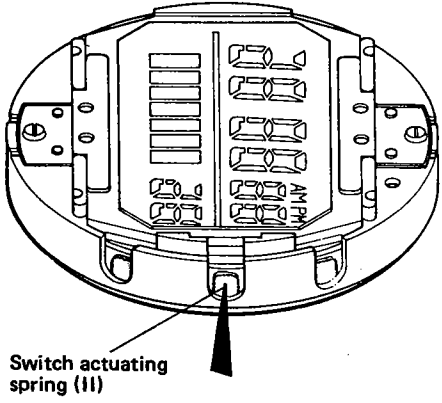
Check item	How to check	Results	Treatment
<p>7 Check of digit selection mechanism.</p>	<p>The digit selection for display is impossible in the following sequent order: "Second" → "minute" → "hour" → "date" → "month" → "year" → "day".</p> <p>For the reason of the above inconvenience, the electrical factor (some troubles in electronic circuit) or mechanical factor (imcomplete contact, parts deformation or breakage) may be considered.</p> <p>Conduct a check for the above in the following procedure.</p> <p>Take out the movement from the watchcase.</p> <p>Push the switch actuating spring (II) with a tweezers, and confirm that the digit selection is possible for "second", "minute", "hour", "date", "month", "year" and "day" in that order.</p>  <p>Switch actuating spring (II)</p>	<p>Digit selection possible</p> <p>Digit selection impossible</p>	<p>No trouble with electrical factor ⑩ Check of operation buttons.</p> <p>⑨ Check of switch actuating spring mechanism</p>

No lamp lighting

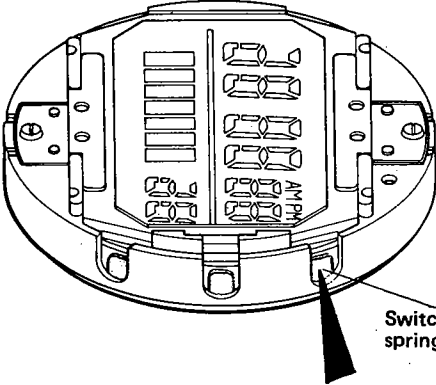
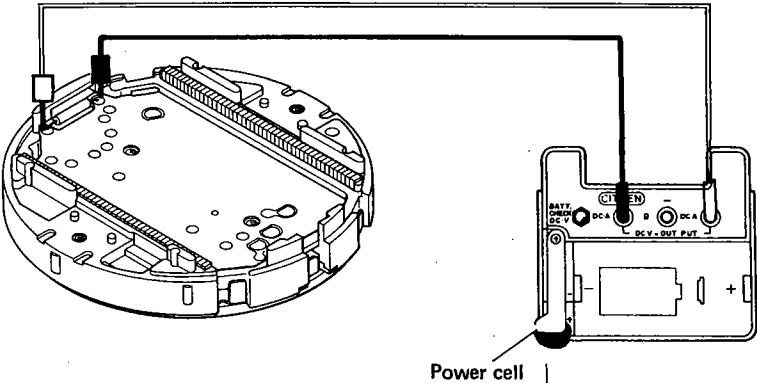
Check item	How to check	Results	Treatment
<p>8 Check of lamp lighting mechanism</p>	<p>When the illumination lamp does not light up by push of the light button, the electrical factor (troubles with lamp itself) or mechanical factor (incomplete contact, deformation or damage of parts, etc.) may be considered. Check for the above in the following procedure.</p> <p>Take out the movement from the watchcase.</p> <p>1) Push the switch actuating spring (I) with a tweezers and confirm that the lamp lights up.</p>  <p>2) Check of lamp As illustrated below, apply citizen Multi-Tester adaptor to both lamp terminals attached to the plate, complete, and check whether the lamp lights up or not.</p> 	<p>Lamp lighting →</p> <p>No lamp lighting →</p> <p>Lamp lighting →</p> <p>No lamp lighting →</p>	<p>⑩ Check of operation buttons</p> <p>2) Check of lamp</p> <p>⑨ Check of switch actuating spring</p> <p>Replacement of plate, complete</p>

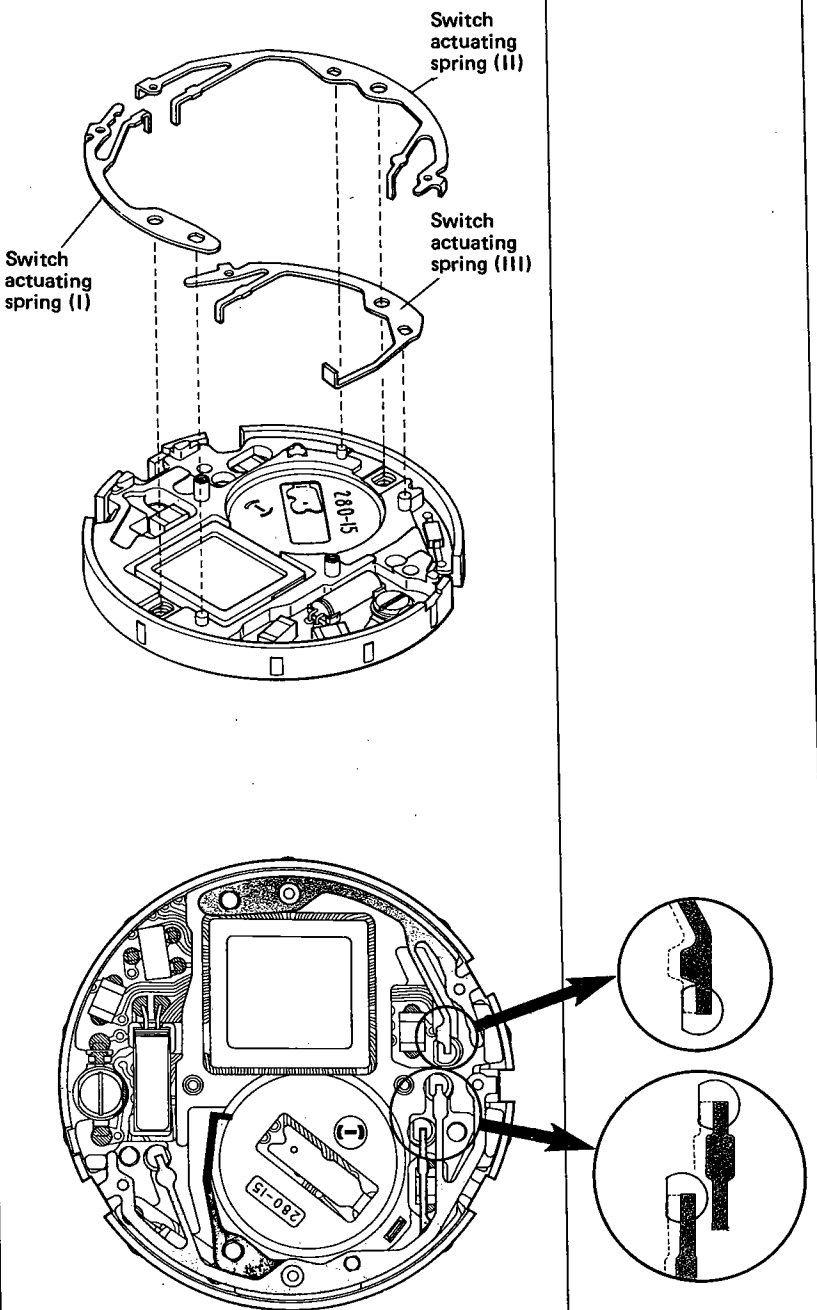
Check item	How to check	Results	Treatment
<p>9 Check of switch actuating spring mechanism</p>	<p>1) Check whether the switch actuating spring (I), (II) and (III) have some deformation or breakage.</p> <p>2) Push the switch actuating spring (I), (II), and (III), and check whether each switch actuating spring touch properly the gold-color pattern of the plate complete.</p> 	<p>Deformation or breakage</p> <p>No contact to gold-color pattern</p> <p>Good contact to gold color pattern</p>	<p>Replacement of springs</p> <p>Replacement of springs</p> <p>Replacement of plate complete</p>

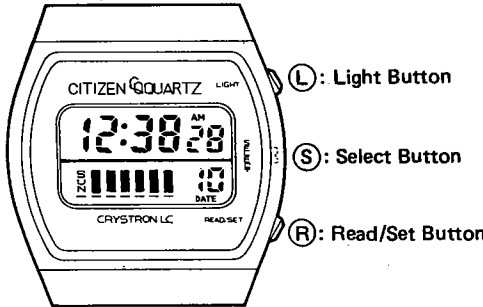
Check item	How to check	Results	Treatment
<p>10 Check of operation buttons</p>	<p>If there is no trouble with the electrical factor (electronic circuit), the cause of trouble may be in the mechanical factors. Conduct check in the following procedure.</p> <ol style="list-style-type: none"> 1. Check (S) (Select) (R) (Read/set) and (L) (Light) buttons as follows. <ol style="list-style-type: none"> 1) Make sure that the operation of each button must be smooth is smooth. 2) Check whether the dust or thread waste etc. are attached to the pipe of each setting button. 3) Isn't each button bent? <p>Note: The check for 2) and 3) can be performed more quickly by removing each button from watchcase.</p> <div style="text-align: center;">  <p>(L): Light Button (S): Select Button (R): Read/Set Button</p> </div>	<p>Dust sticked nized Deformation or breakage of buttons</p>	<p>→ Removal → Replacement of buttons</p>

Common checking items

11 Measurement of power cell voltage

Power cell voltage: Over 1.5V

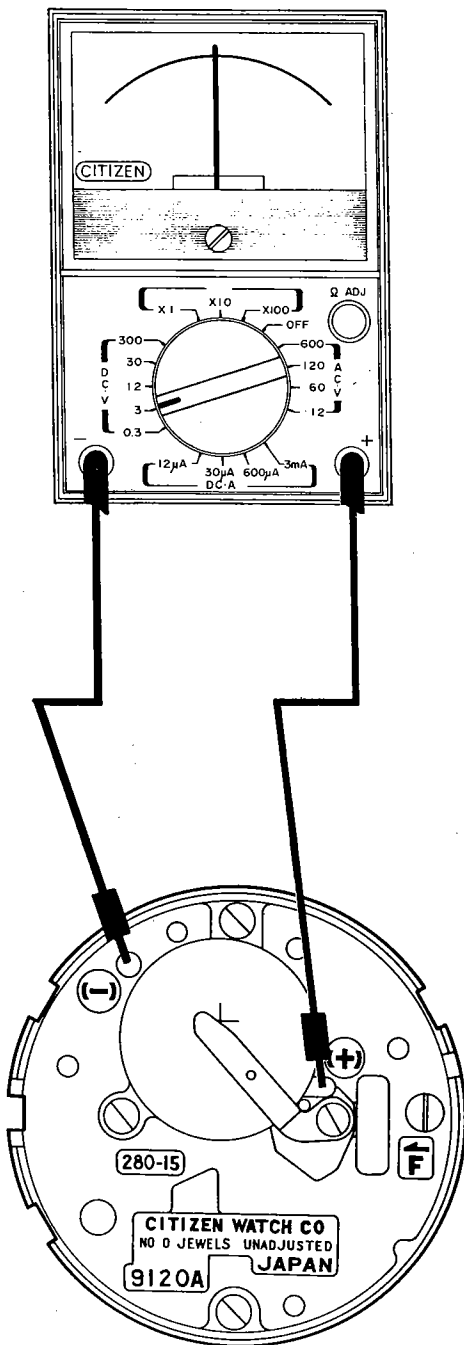

Result and Treatment

Over 1.5V

- Correct display of LC display panel
→ ⑫ Measurement of power consumption
- No display of LC display panel
→ Replacement of plate.

Under 1.5V

Replace power cell:

- Correct display of LC display panel
→ ⑫ Measurement of power consumption
- No display of LC display panel
→ Replacement of plate

Note

If the watch has been used more than two years, replace the power cell with the new one even if it shows more 1.5V output power.

How to Install Power Cell

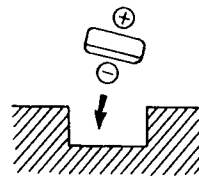

When installing power cell into the watch, make the minus (-) side face down.

12 Measurement of power consumption

Power consumption = Under $4.0\mu\text{A}$

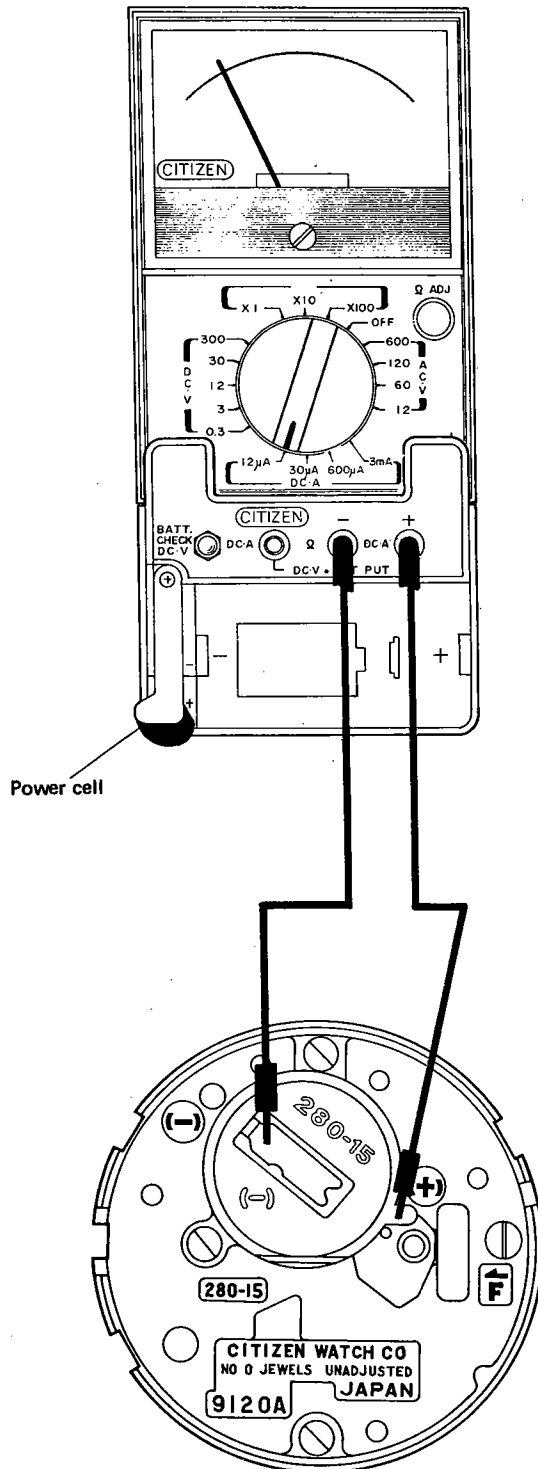

Result and Treatment

(1) Measurement under normal condition:

Under $4.0\mu\text{A}$

→ ⑬ Time adjustment

Over $4.0\mu\text{A}$

→ (2) Measurement of power consumption of electric circuit section

(2) Measurement of power consumption of electronic circuit section with LC display panel removed:

Under $2.0\mu\text{A}$

→ Replace LC display panel connection rubber for electrical contact or LC display panel.

Over $2.0\mu\text{A}$

→ Replacement of plate, complete

Note

Install a power cell of more than 1.5V into the power cell holder of the adapter.

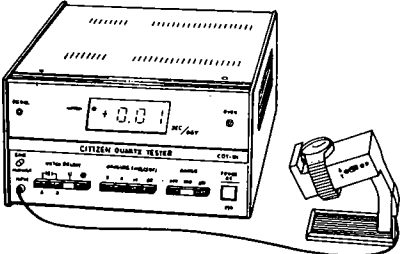
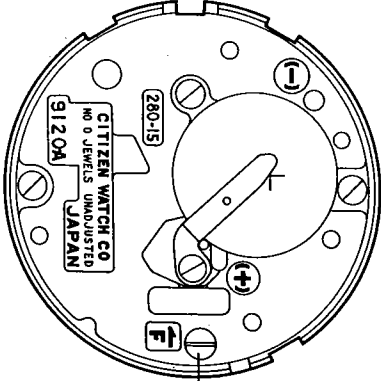
Check item	How to check	Results	Treatment
<p>13 Time adjustment</p>	<p>Set the microphone for liquid crystal use to the Quartz-timer to measure the time rate.</p>  <p>The time rate adjustment can be performed by turning right or left the head of the screw of the trimmer condenser.</p>  <p>Trimmer condenser</p>		

Check item	How to check	Results	Treatment
14 Check of appearance functions	<p>When completing all the above checks and adjustments, conduct finally the following checks for the appearance functions.</p> <ol style="list-style-type: none"> 1. Confirm there is no trouble with displayed figures and other factors displayed on the time screen. 2. Push the read/set button (R), and check whether the normal time display changes properly to the calendar display. 3. Operate both (S)- and (R) buttons and confirm 0-second resetting and other digit correction can be correctly performed. 4. Push both (R) and (L) buttons simultaneously, and check whether the display switching is possible between 24-hour and 12-hour periods. 5. Push (L) button and confirm the illumination lamp instantly lights up. 6. Confirm there is no dust nor stains stuck to the appearance parts. <div style="text-align: center; margin-top: 20px;">  <p>(L) : Light button</p> <p>(S) : Select button</p> <p>(R) : Read/Set button</p> </div>		

CITIZEN WATCH CO., LTD.
Tokyo, Japan