

TECHNICAL INFORMATION

CITIZEN QUARTZ

Cal. No. 8410



 **CITIZEN**
CITIZEN IS A REGISTERED TRADEMARK OF CITIZEN WATCH CO., JAPAN.

Contents

§1. SPECIFICATIONS	1
§2. CONCRETE USAGE OF THIS WATCH	2
§3. NAME OF EACH PART	3
§4. HOW TO CHANGE THE MODE	4
§5. RECEIVING FUNCTIONS OF THIS WATCH	4
1) Automatic receiving function	4
Function to find out the most efficient direction for receiving –	
Directivity check function	5
2) Forced receiving function	5
3) Reset of receiving	7
4) Function to confirm receiving result	7
5) Precautions for receiving in Japan	7
6) Places where receiving is difficult	8
7) Rough borders of areas where receiving is possible	8
8) Tips for receiving satisfactorily	8
§6. SUMMER TIME FUNCTION	9
§7. MANUAL TIME CORRECTION METHOD	9
§8. MANUAL CALENDAR CORRECTION METHOD	10
§9. HOW TO USE LOCAL TIME	11
§10. HOW TO USE THE ALARM	12
§11. ZERO POSITION CHECK MODE	13
§12. REPLACEMENT PROCEDURE FOR POWER CELL	16
§13. MOUNTING PROCEDURE FOR HANDS	19
§14. MEASUREMENT PROCEDURE FOR CURRENT CONSUMPTION	21
§15. PRECAUTIONS FOR DISASSEMBLY AND ASSEMBLY	23
§16. DISASSEMBLY AND ASSEMBLY OF MODULE	25
§17. TROUBLESHOOTING AND ADJUSTMENT	29

§1. SPECIFICATIONS

Caliber No.	8410-09M
Type	Multi-hand analog quartz watch
Oscillation	32768 Hz (Hz = Vibrations in 1 sec)
Accuracy	Average error at normal temperature (5 °C ~ 35 °C): ±15 sec/month
Effective temperature range	-10 °C ~ 60 °C (14 °F ~ 140 °F)
Additional functions	<ul style="list-style-type: none"> • Automatic receiving function – Automatically receives radio wave at 2 o'clock in the midnight every even-number day of each month and at 4 o'clock in the morning every odd-number day to correct the time and date (EUR, UK, JPN mode). Date is not corrected, however, in JPN mode. • Forced receiving function – (EUR, UK, JPN modes) • Function to confirm receiving result – (EUR, UK, JPN mode) • Directivity check function – (EUR, UK, JPN, LTM mode) • One-touch summer time changing function – (EUR, UK, JPN, LTM mode) • Summer time monitor function – (EUR, UK, JPN, LTM mode) • Local time function – Time difference is corrected by 1 hour. Second hand and date cannot be corrected.
Power cell	280-206 (Power cell code CR2016)
Power cell lifetime	Approx. 2 years (Automatic receiving: 1 time/day, forced receiving: 1 time/week, alarm: 1 time/day)

* The power cell lifetime depends on the using frequency of each function.

<The specifications are subject to change without prior notice for product improvement.>

§2. CONCRETE USAGE OF THIS WATCH

The basic functions of this watch will be explained below so that you will easily understand how to use it.

- (1) See in which receiving area of Europe, United Kingdom and Japan you are now, then select the corresponding mode.

For the detail, see "How to change the mode". For the areas where receiving is possible, see "Rough borders of areas where receiving is possible".

For example, if you are in Japan, press the **M** button to select the JPN mode.

- (2) Find out a place where you can receive the radio wave easily.

For higher efficiency of the receiving functions of this watch, set its antenna in the direction to receive the radio wave the most efficiently.

For convenience, you should find a place in your house at which your watch can receive the radio wave efficiently.

For the detail, see "Receiving functions of this watch".

For example,

It is difficult to receive the radio wave in a metal box or near an electric device which blocks the radio wave.

You should receive the radio wave by a window near which there are less electric devices.

Find out the best place to receive the radio wave by using the "directivity check function".

Do not widely change the direction of the antenna while receiving, for stable receiving.

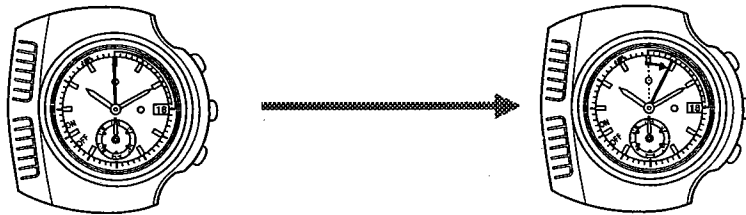
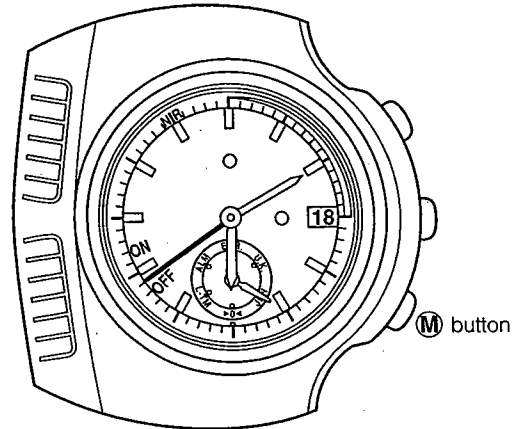

Turn on the forced receiving function several times with the watch in different directions to find out a place and a direction of the antenna at which the second hand moves the most widely.

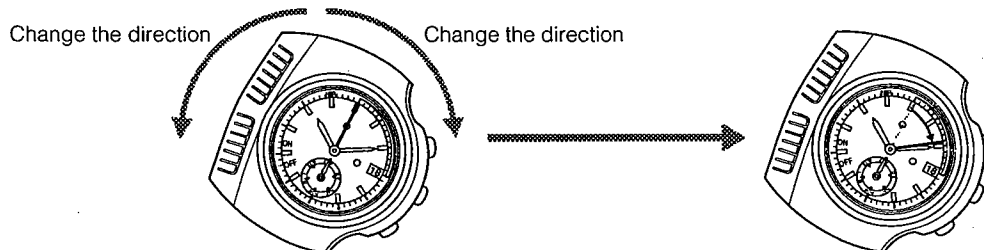

- After the directivity check function is executed, if the receiving condition is stabilized, the LED flashes at the interval of 3 seconds.
After the receiving is stabilized, it may become unstable and receiving may be stopped for some reasons.
In this case, find out a place again where the radio wave can be received efficiently.
- In a place where the radio wave cannot be received at all, even the directivity check function does not work and receiving is turned off.

(3) How to set the time every day

No particular operation is required. This watch receives the radio wave automatically once a day, at midnight or early morning to set the time. For this purpose, place the watch in the place to receive the radio wave efficiently which was found out in (2) above.

For the detail, see "automatic receiving function".

Even if the watch cannot receive the radio wave at the automatic receiving time, you can receive the radio wave in a better place.

For the detail, see "forced receiving function".

§3. NAME OF EACH PART

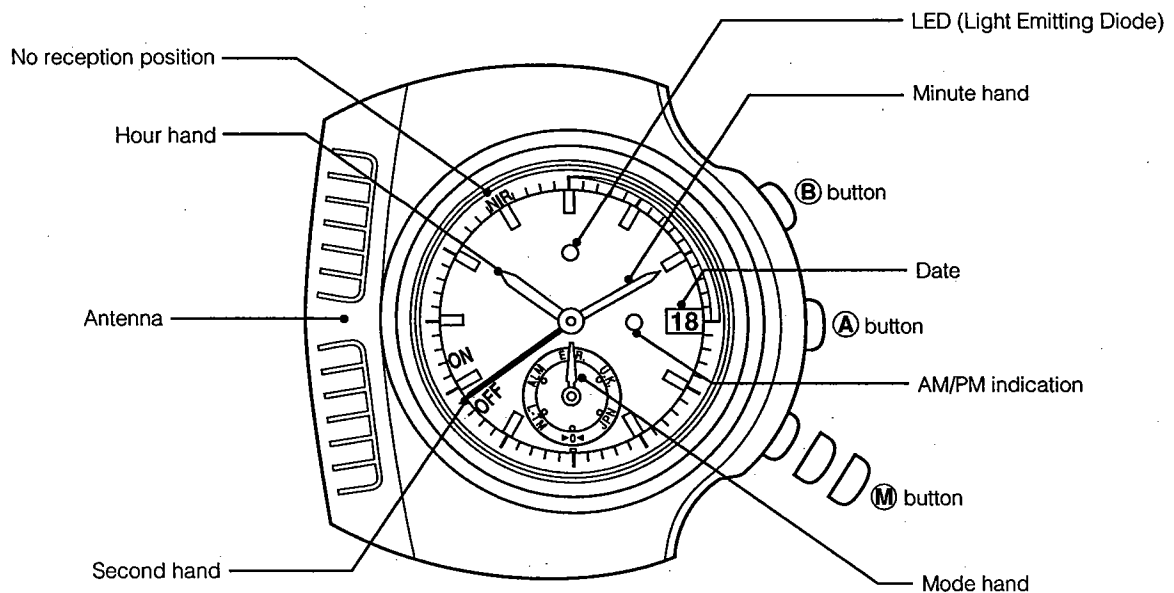

§4. HOW TO CHANGE THE MODE

This watch has six functions, each of which is selected with the push button.

How to use

(1) The functions can be switched by pressing the **(M)** button in the following sequence.

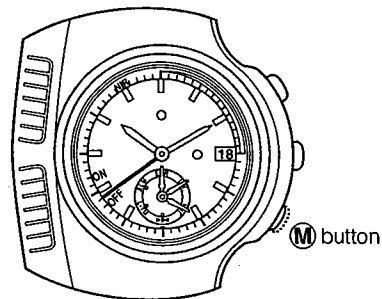
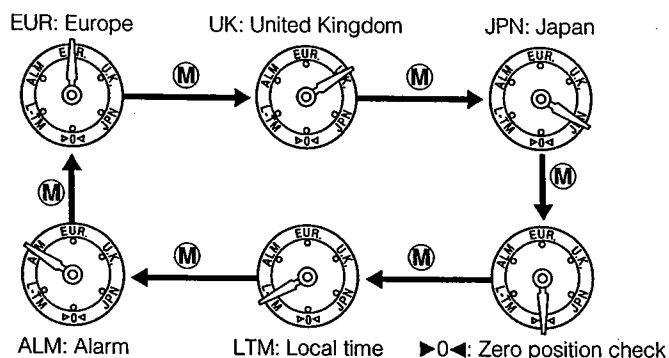

§5. RECEIVING FUNCTIONS OF THIS WATCH

1) Automatic receiving function

This watch sets itself to the correct time automatically.

This watch receives the radio wave to correct itself automatically at midnight or early morning when the radio wave is relatively stabilized.

How to use

- (1) This function is effective in the EUR, UK or JPN modes. Press the **(M)** button to select the correct area.
- (2) This watch automatically receives the radio wave at 2 o'clock in the midnight every even-number day of each month and at 4 o'clock in the early morning every odd-number day.

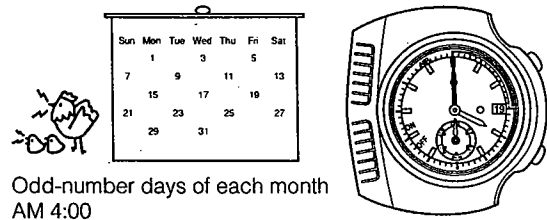
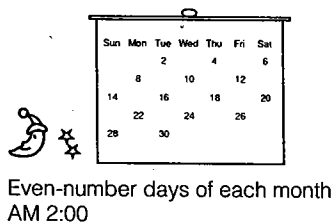
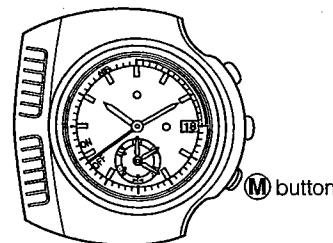

- (3) A while after the watch starts receiving, the "directivity check function" works. Then, the second hand stops at a position between 0 second and 15 seconds. If the watch receives the radio wave more efficiently, the second hand moves to the right more.

* If the summer time changed to the winter time after it automatically received the radio wave, receive the radio wave again or correct the time manually.

Function to find out the most efficient direction for receiving – Directivity check function

It is necessary to set the antenna of this watch in the best direction for receiving the radio wave to use the receiving function the most efficiently.

This function is used to find out the best direction for receiving.

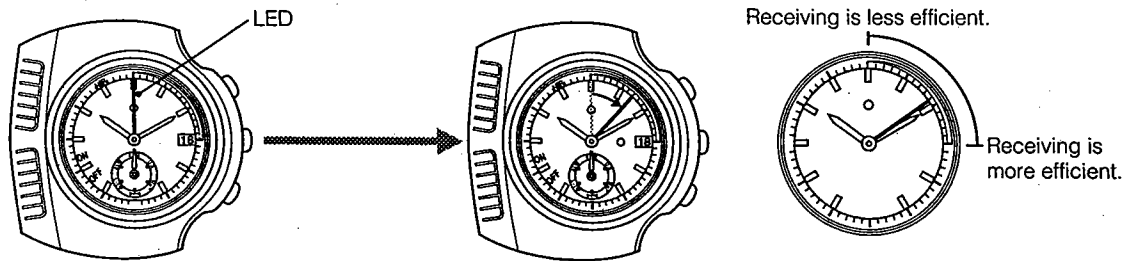

- After the receiving is stabilized, it may become unstable and receiving may be stopped for some reasons.
In this case, find out a place again where the radio wave can be received efficiently.
 - In a place where the radio wave cannot be received at all, even the directivity check function does not work and receiving is turned off.
 - Do not widely change the direction of the antenna while receiving, for stable receiving.
 - This watch takes 2 - 8 minutes to receive the radio wave each time. It indicates the time normally again after receiving is finished, regardless of the result of receiving.
- (4) Find out the best place and direction to receive the radio wave with the forced receiving function in the daytime.
- Then, place the watch on that place for secure receiving.

Even if the watch fails in receiving the radio wave, it indicates the time and calendar before it started receiving.

2) Forced receiving function

- Even if the watch failed in receiving the radio wave at the automatic receiving time, you can receive the radio wave in a better place.

How to use

- (1) This function is effective in the EUR, UK or JPN modes. Press the **M** button to select the correct area.

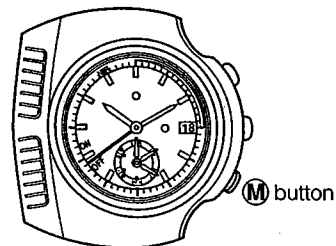

- (2) Turn on the forced receiving function. Press and hold the **(B)** button until a confirmation pip sound comes out, then release it.

The second hand stops at the 0 second position.

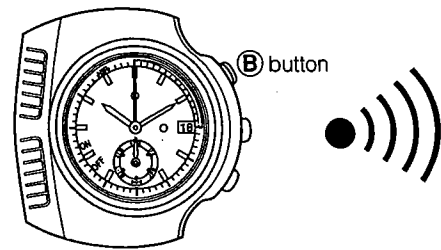

- (3) A while after the watch starts receiving, the "directivity check function" works as in the forced receiving operation. Then, the second hand stops at a position between 0 second and 15 seconds.

If the watch receives the radio wave more efficiently, the second hand moves to the right more.

Directivity check function

It is necessary to set the antenna of this watch in the best direction for receiving the radio wave to use the receiving function the most efficiently.

This function is used to find out the best direction for receiving.

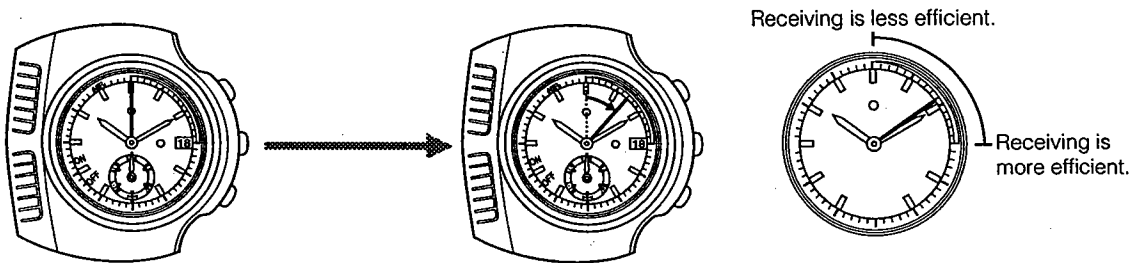

- After the directivity check function is executed, if the receiving condition is stabilized, the LED flashes at the interval of 3 seconds. After the receiving is stabilized, it may become unstable and receiving may be stopped for some reasons. In this case, find out a place again where the radio wave can be received efficiently.
 - If receiving is finished normally, some confirmation pip sounds come out to notify finish of receiving.
 - In a place where the radio wave cannot be received at all, even the directivity check function does not work and receiving is turned off. If the watch fails in receiving the radio wave, one confirmation pip sound comes out.
 - Do not widely change the direction of the antenna while receiving, for stable receiving.
 - This watch takes 2 - 8 minutes to receive the radio wave each time. It indicates the time normally again after receiving is finished, regardless of the result of receiving.
- (4) Find out the best place and direction to receive the radio wave with the forced receiving function in the daytime.

Then, place the watch on that place for secure receiving.

Even if the watch fails in receiving the radio wave, it indicates the time and calendar before it started receiving.

3) Reset of receiving

- The automatic receiving or forced receiving operation in each receiving mode can be reset by changing the mode with the **(M)** button or by pressing and holding any button for 1 second.

4) Function to confirm receiving result

- The results of the latest automatic receiving and forced receiving can be confirmed.

How to use

(1) The receiving results can be confirmed only in the EUR, UK or JPN mode.

(2) Press the **(B)** button.

(3) If receiving failed, the second hand indicates NR.

NR: No Reception

If receiving succeeded, the second hand is between 0 second and 15 seconds and the result of the directivity check is indicated and the LED flashes.

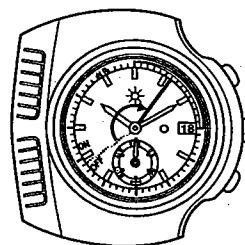
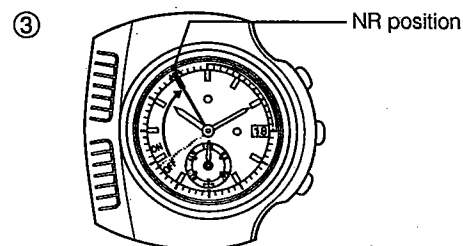
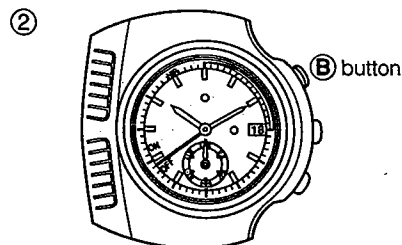

5) Precautions for receiving in Japan

- This watch receives the Japanese standard time radio wave transmitted from an experimental station by the General Communication Study Institute of the Ministry of Posts and Telecommunications for experiments. Accordingly, it is not assured that this radio wave will be transmitted permanently as it is.

Even if the above radio wave is stopped or its form or contents are changed in the future, however, this watch can be used as a common quartz watch (Accuracy: 15 sec/month).

Since this watch can receive the standard time radio waves of the Middle Europe and United Kingdom, it can be used as a radio wave watch in those areas.

Precautions for receiving

The Japanese standard time radio wave can be received basically at any time through 24 hours. It cannot be received, however, for 1 minute each after 15 minutes and 45 minutes after every hour because of transmission of JG2AS call sign. In addition, it is interrupted occasionally since it is transmitted from the experimental station.

When the standard time radio wave is received in Japan, this watch is set to the correct time but its calendar is not set. Accordingly, set the calendar manually. If the watch is set by receiving the radio wave or by manual operation in another receiving area, however, the calendar is set automatically.

6) Places where receiving is difficult

Avoid receiving the radio wave in a place where the watch may receive radio wave noises. To be concrete, the watch may not receive the radio wave normally.

- ① In a building or between buildings
- ② In a car, train or airplane
- ③ Near high-tension lines or train line
- ④ Near electric appliances in your home or an office, such as a television, refrigerator, personal computer, facsimile, etc.

Do not receive the radio wave in the above places.

7) Rough borders of areas where receiving is possible

The rough borders of the areas where this watch can receive the standard time radio wave are shown in the following table. They depend on the time and season, however.

Receiving mode	Standard time radio wave transmitting station	Address of transmitting station	Rough borders of areas where receiving is possible
EUR (Middle Europe)	DCF77	MAINFLINGEN, Germany (25 km South east of Frankfurt)	Radius of 900 km (Radio wave may not be received normally near the Lake Léman.)
UK (United Kingdom)	MSF	RUGBY, United Kingdom	Radius of 500 km
JPN (Japan)	JG2AS	Sanwa-cho, Ibaragi-ken	Radius of 500 km

8) Tips for receiving satisfactorily

Since the radio wave is blocked by metallic items, receive it by a window when in a reinforced concrete building.

Do not widely change the direction of the antenna while receiving, for stable receiving.

(Example)

For automatic receiving: Place the watch on a place where the receiving condition seems better before going to bed.

For forced receiving: Take off the watch or keep its antenna in one direction while receiving the radio wave.

§6. SUMMER TIME FUNCTION

This watch can be set for the summer time in the EUR, UK, JPN and LTM modes.

Summer time monitor

- This function is used to see if the watch is set for summer time at present.

- (1) Press the **(A)** button in the EUR, UK, JPN or LTM mode.

(Meaning of flash of LED)

LED flashes once: The watch is indicating the standard time.

LED flashes twice: The watch is indicating the summer time.

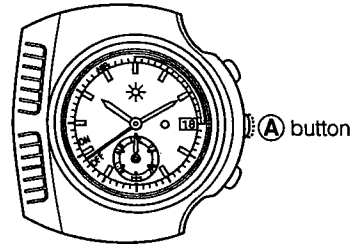

How to set for summer time

- (1) Press the **(M)** button to select EUR, UK, JPN or LTM mode to be set for the summer time.
- (2) Press and hold the **(A)** button for 2 seconds, then release it. At this time, the LED flashes once or twice and the summer time is set or reset.

(Meaning of flash of LED)

LED flashes once: The watch is set for the summer time.

LED flashes twice: The watch is set for the standard time.

§7. MANUAL TIME CORRECTION METHOD

This watch can be set to the correct time manually, even if it cannot receive the radio wave.

How to set time

- (1) Pull out the **(M)** button to the second position.

①

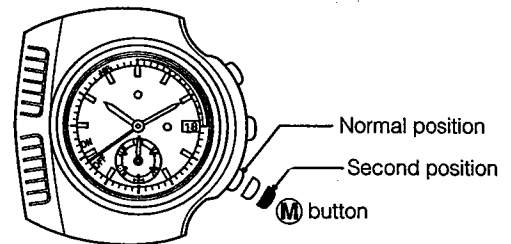

- (2) Press the **(A)** button to set the second hand.

②

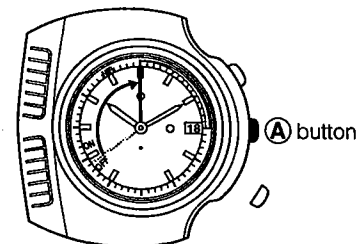

(3) Press the **(B)** button to set the hour and minute hands.

- The hour and minute hands can be turned clockwise (to the right) only.
- When setting the time, take care of the picture plate to indicate AM/PM.

③

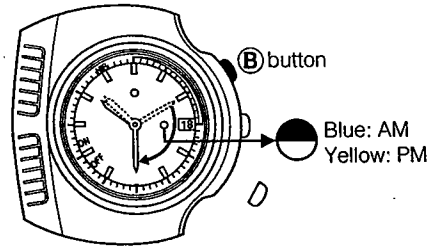

* How to read picture plate to indicate AM/PM

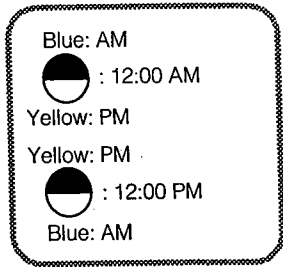

(4) After setting the time, push in the **(M)** button to the normal position.

§8. MANUAL CALENDAR CORRECTION METHOD

The calendar of this watch can be set manually, even if it cannot receive the radio wave.

How to set calendar

(1) Pull out the **(M)** button to the first position.

(2) Press the **(A)** button to set the watch to the number of years after the last leap year.

- Referring to the figure below, set the second hand to the position of the number of years after the last leap year in the section of the current month.

①

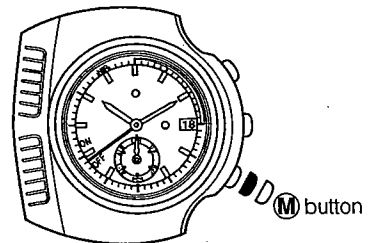

Example

If it is December of a leap year, set the second hand to the 12 o'clock position.

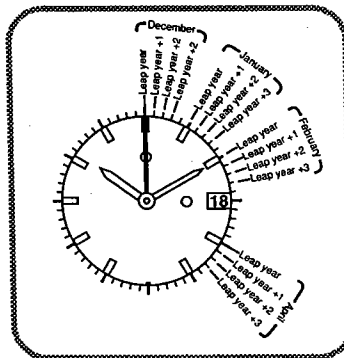

②

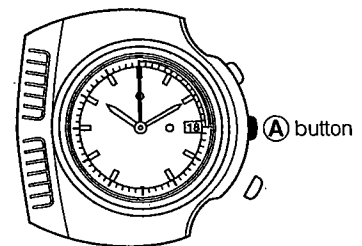

(3) Press the **(B)** button to set the date.

- The calendar can be turned clockwise (to the right) only.

(4) After setting the calendar, push in the **(M)** button to the normal position.

③

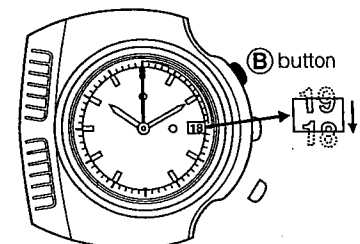

§9. HOW TO USE LOCAL TIME

This watch can be set to the times of the three areas (EUR/UK/JPN) and one additional local time. In the local time mode, however, the standard time radio wave cannot be received.

The time difference of the local time can be set by 1 hour.

How to use the local time watch

- (1) Press the **(M)** button to set the watch in the LTM mode.



How to set local time

- (1) Press the **(M)** button to set the watch to the LTM mode.

- (2) Pull out the **(M)** button to the second position.

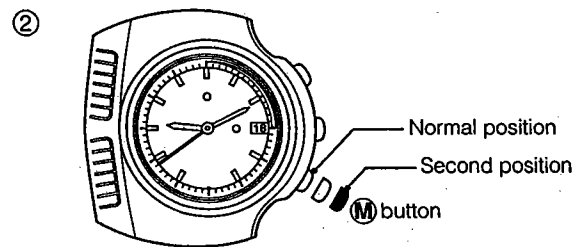

- (3) Press the **(A)** button to set the hour and minute hands counterclockwise (to the left).

Press the **(B)** button to set the hour and minute hands clockwise (to the right).

- The time is corrected by 1 hour in the local time mode.
- The second hand and calendar cannot be corrected.

- (4) After setting the local time, push in the **(M)** button to the normal position.

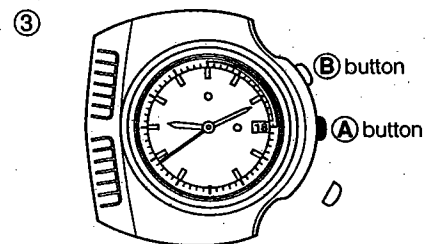

§10. HOW TO USE THE ALARM

If this alarm is set, it sounds for about 15 seconds at the set time every day. Accordingly, you can use this watch as an alarm watch.

The alarm sounds at the time of the indicated area.

How to set the alarm

- (1) Press the **(M)** button to set the watch to the ALM mode.

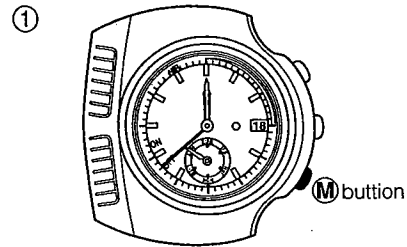

- (2) Pull out the **(M)** button to the second position.

- If the **(M)** button is pulled out, the alarm is automatically turned on.

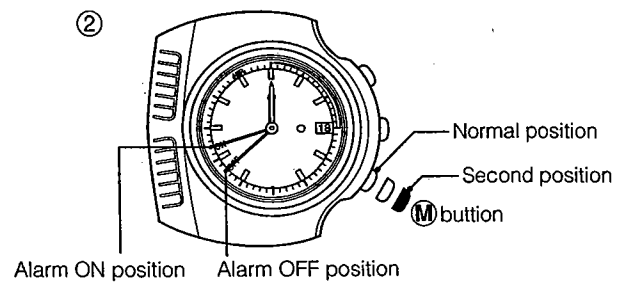

- (3) Press the **(A)** button to set the hour and minute hands counterclockwise.

Press the **(B)** button to set the hour and minute hands clockwise.

When setting the alarm time, take care of the picture plate to indicate AM/PM.

- (4) After setting the alarm, push in the **(M)** button to the normal position.

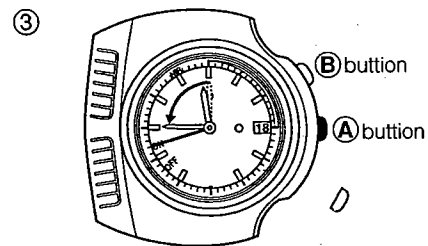

How to reset the alarm

- (1) Press the **(M)** button to set the watch to the ALM mode.

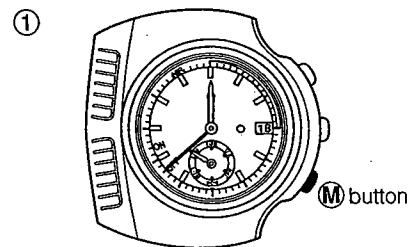

- (2) Press the **(A)** button, and the confirmation pip sound comes out and the second hand is changed from ON to OFF indication, and the alarm is reset.

If the **(A)** button is pressed again, the alarm is turned on.

- The alarm can be turned ON and OFF while the hour and minute hands are moving for a change the mode.

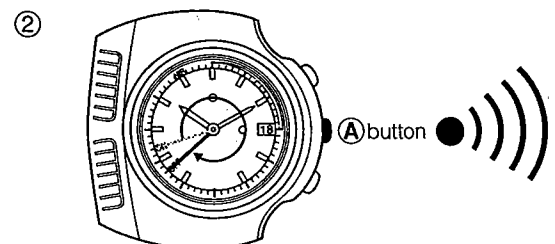

§11. ZERO POSITION CHECK MODE

After the power cell is replaced or a large shock is given to the watch, be sure to check the standard positions of the hands (zero position) in this mode.

How to check

- (1) Press the **(M)** button to set the watch to the **▶0◀** mode.
 - Confirm that each hand, picture plate and date dial are at the following positions.

- Second hand: 0 second
- Hour and minute hands and picture plate of AM/PM interlocked with them: 12: 00 AM
- Date dial: Mark of ◀

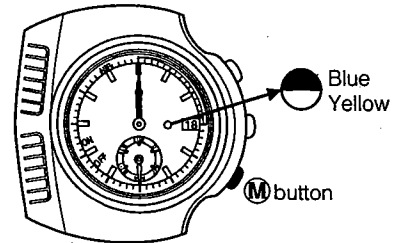

- (2) If each hand is at the normal position, set the time and calendar by hand or by receiving the radio wave.

— If the watch is not at the zero position, correct it by the method described below. —

How to set the watch to the zero position

If the watch is not at the zero position when it is checked for the zero position, correct it according to the following procedure.

- (1) Press the **(M)** button to set the watch to the **▶0◀** mode.

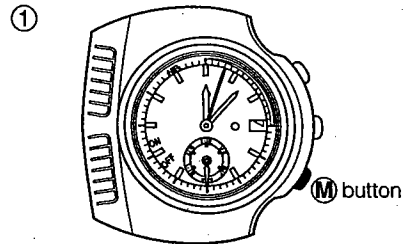

- (2) Pull out the **(M)** button to the first position.

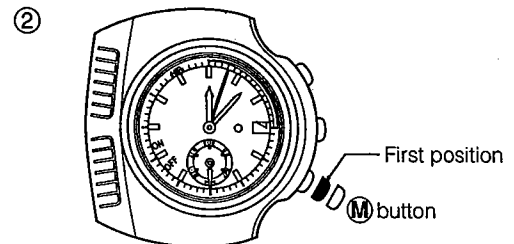

- (3) Press the **(A)** button to set the date dial counterclockwise to the zero position.
Press the **(B)** button to set the date dial clockwise to the zero position.

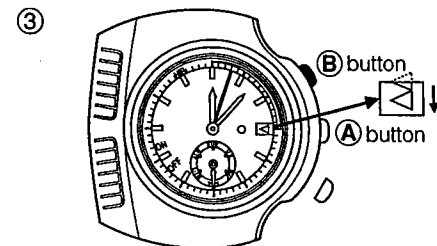

- (4) Pull out the **(M)** button to the second position.

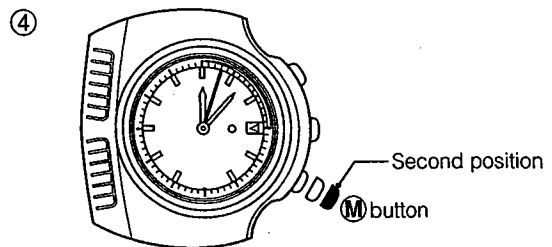

- (5) Press the **(A)** button to set the second hand to the zero position.

- The second hand can be turned clockwise (to the right) only.

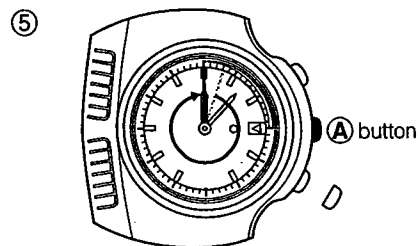

- (6) Press the **(B)** button to set the hour and minute hands to the zero position.

- The hour and minute hands can be turned clockwise (to the right) only.

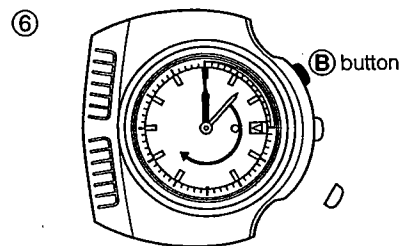

- (7) After setting the watch to the zero position, push in the **(M)** button to the normal position.

After the above setting, press the **(M)** button to set the watch to a desired area mode, then perform the forced receiving.

If you are in a place where you can receive the standard time radio wave, the watch indicates the present time and date several minutes after.

If you are in Japan, however, the date is not set automatically.

If you are in a place where you cannot receive the radio wave, set the time and calendar by hand.

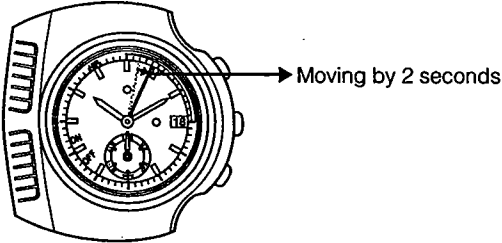
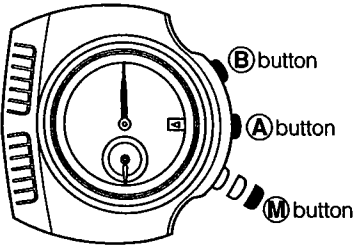
Trouble	Checkpoints	Countermeasures
The watch does not receive radio wave.	<p>See if the second hand moves as shown below.</p> 	<p>If the second hand moves as shown at left, the power cell is almost dead. Consult the shop from which you bought your watch or a shop which sells CITIZEN quartz watches.</p>
Radio wave cannot be received.	<ul style="list-style-type: none"> • Is the correct area mode selected? • Are you in the area where receiving is possible? 	<ul style="list-style-type: none"> • Press the (M) button to select the correct area mode. • See "Rough borders of areas where receiving is possible" in this manual.
Radio wave cannot be received (in a place where it was received before).	<ul style="list-style-type: none"> • Check for items which block radio wave or generate noises. 	<ul style="list-style-type: none"> • See "places where receiving is difficult" and "tips for receiving satisfactorily" in this manual. • Check for change of receiving condition caused by change of arrangement of furniture, etc.
The watch received radio wave but does not indicate the correct time.	<ul style="list-style-type: none"> • See if each hand is at the zero position in the zero position check mode. • Check for items which block radio wave or generate noises. • See if you are on a border of the area where receiving is possible. 	<ul style="list-style-type: none"> • Set each hand to the zero position in the zero position check mode explained in this manual. • See "places where receiving is difficult" and try again to receive radio wave.
The watch moves or indicates abnormally.	<ul style="list-style-type: none"> • The hands dose not stop moving. • The watch stopped without any symptom. • Push buttons do not work. • The watch moves abnormally (Except movement of the second hand for notifying the power cell lifetime). 	<ol style="list-style-type: none"> (1) Press the (M) button to set to ▶0◀ mode. (2) Pull out the (M) button to the second position. (3) Press and hold the (A) and (B) buttons simultaneously for 2 seconds, then release them. (4) Return the (M) button to the normal position. <p>A confirmation sound comes out and the LED flashes once. Then, the hour, minute, second and date dial move for demonstration (All-reset operation is finished).</p> <p>Precaution ! After the above operation, set each hand to the zero position, then set the time and calendar.</p>

§12. REPLACEMENT PROCEDURE FOR POWER CELL

- Press the **M** button to set the watch to ►0◀ mode.
- Replace the power cell with the module in the case.

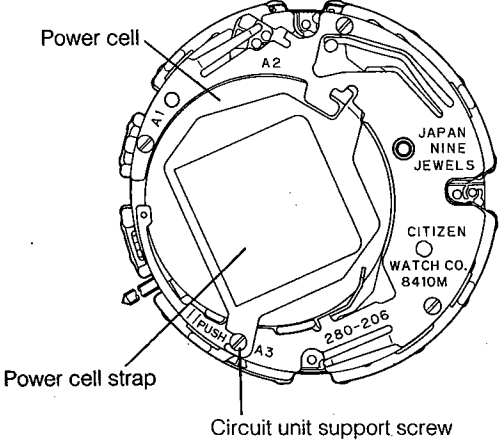
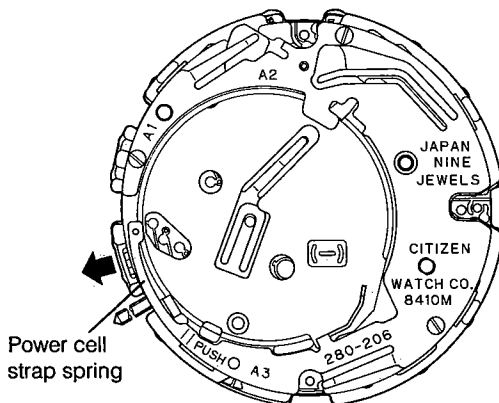

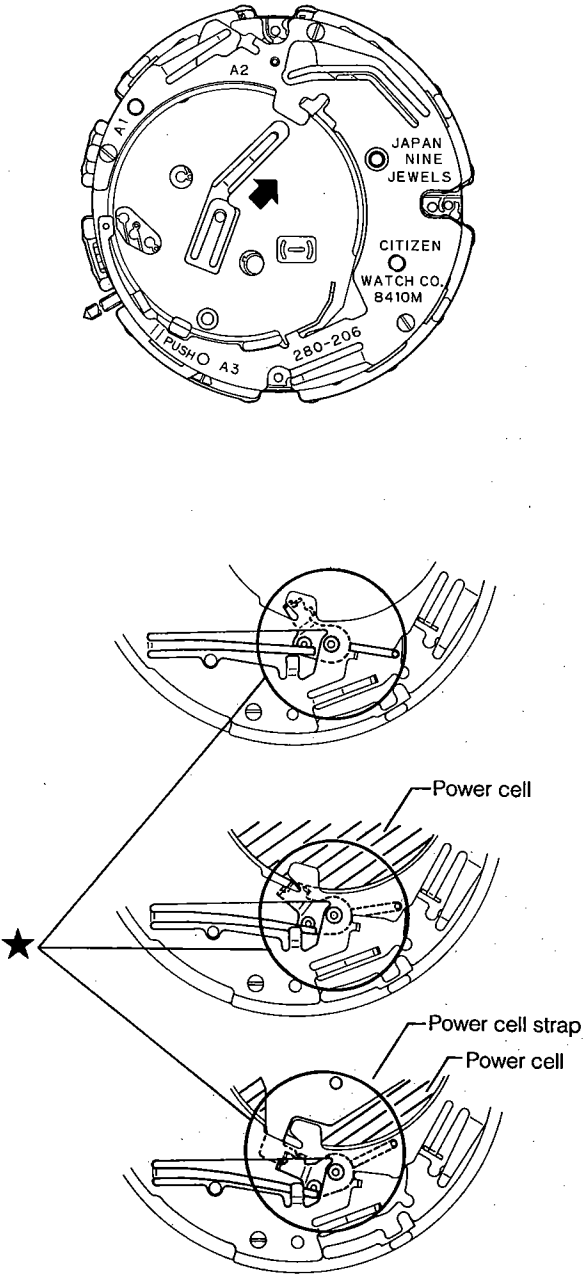
Step	Explanatory Drawing	Precautions
<p>① Loosen the circuit unit support screw to remove the power cell strap.</p>	 <p>The diagram shows the internal layout of the watch case back. A rectangular power cell is positioned at the top. A strap is attached to the bottom of the power cell. A screw is used to secure the circuit unit support. Labels point to various components: 'Power cell', 'A2' (top), 'JAPAN NINE JEWELS' (right), 'CITIZEN WATCH CO. 8410M' (right), '280-206' (bottom), 'A3' (bottom), 'CIRCUIT UNIT SUPPORT SCREW' (bottom), and 'POWER CELL STRAP' (bottom).</p>	
<p>② Remove the power cell strap spring in the direction of the arrow and take out the power cell.</p>	 <p>This diagram illustrates the removal of the power cell strap spring. An arrow points to the spring mechanism on the left side of the case back. Other labels include 'A2', 'JAPAN NINE JEWELS', 'CITIZEN WATCH CO. 8410M', '280-206', and 'A3'.</p>	

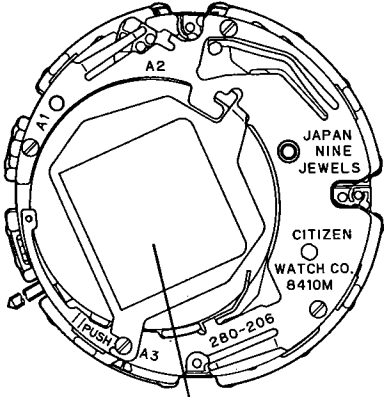
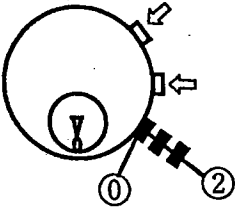
Step	Explanatory Drawing	Precautions
<p>③ Set the power cell.</p>	 <p>★ The above three figures show CAL. 7400. The structure in the circles in these figures is the same as that of CAL. 8410, however.</p>	<p>Set the power cell in the direction of the arrow.</p>
<p>④ Tighten the circuit unit support screw.</p>		

Step	Explanatory Drawing	Precautions
<p>5 All-reset operation after replacement of power cell</p>	<p>This watch memorize the zero-position before replacement of the power cell. Accordingly, it is not necessary to adjust the zero-position, if the all-reset operation is performed.</p>  <p>(Contents of seal)</p> <div style="border: 1px solid black; padding: 10px; margin: 10px 0;"> <p>電池交換後、0位置モードでリューズ2段引きして2つのボタンを同時押し、リューズを戻してください</p> <ol style="list-style-type: none"> 1. After replacing battery. set ▶ 0 ◀ and pull the crown to ② 2. Push 2-PB simultaneously 3. Push the crown to ①  </div>	<p>Press the (A), (B), (C) and (D) buttons at the same time for 2 seconds, then release them. Then,</p> <ul style="list-style-type: none"> • Each hand indicates the zero-position. • The hands move for demonstration as follows. <p>Hour and minute hands: -10 min → +10 min</p> <p>Second hand: 1 turn</p> <p>Date dial: -0.5 days → +0.5 days</p> <p>If the hands do not automatically indicate zero-position for some reason, adjust them manually.</p>
<p>6 Setting of time and calendar</p>	<p>See the setting method for time and calendar.</p>	

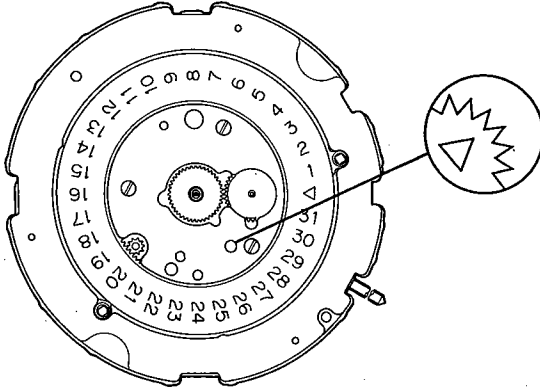
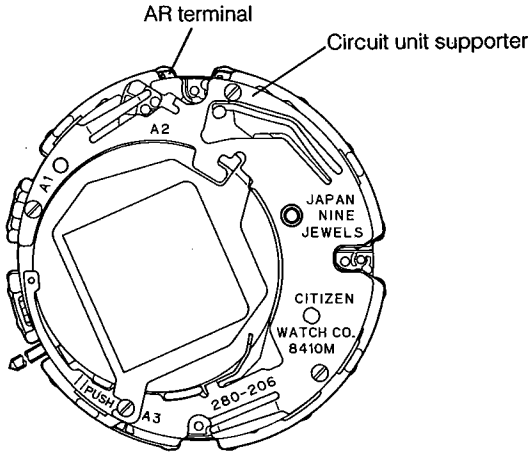
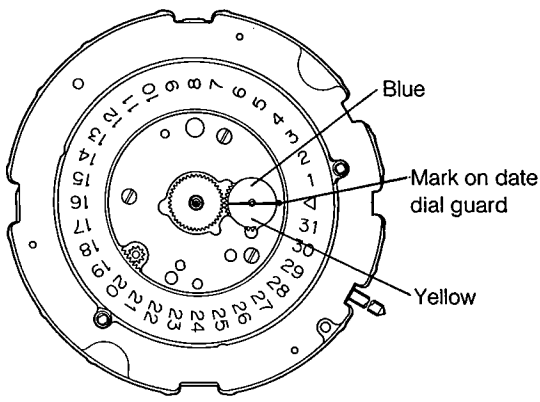
§13. MOUNTING PROCEDURE FOR HANDS

Step	Explanatory Drawing	Precautions
<p>① Set to zero-position mode (▶◀).</p>	<p>Press the M button repeatedly until the mark of the intermediate mode wheel appears in the window shown below.</p> 	
<p>② Perform the all-reset operation.</p>	 <p>AR terminal</p> <p>Circuit unit supporter</p> <p>A2</p> <p>JAPAN NINE JEWELS</p> <p>CITIZEN WATCH CO. 8410M</p> <p>280-206</p> <p>A3</p> <p>PUSH</p>	<p>Connect the circuit unit supporter to AR terminal for at least 2 seconds.</p>
<p>③ Position the day and night dial wheel.</p>	<p>Turn the day and night dial driving wheel (metallic) to match the border of the print of the picture wheel to the mark on the date dial guard.</p>  <p>Blue</p> <p>Mark on date dial guard</p> <p>31</p> <p>Yellow</p>	<p>Do not touch the day and night dial wheel and day and night driving wheel.</p>

Step	Explanatory Drawing	Precautions
<p>④ Set the dial washer and hour wheel.</p>	<p>Dial washer </p> <p>Hour wheel </p>	<p>When setting the hour wheel, confirm that the border line of the day and night dial wheel is matched to the mark on the date dial guard.</p>
<p>⑤ Mount the dial.</p>		
<p>⑥ Mount the mode hand.</p>	<p>Mount the mode hand to the center of the print of "▶0◀".</p>	
<p>⑦ Mount each hand.</p>	<p>Mount the hour, minute and second hands to the position of 12:00:00.</p>	
<p>⑧ Set the module in the case.</p>		

§14. MEASUREMENT PROCEDURE FOR CURRENT CONSUMPTION

Measure the current consumption with the module in the case.

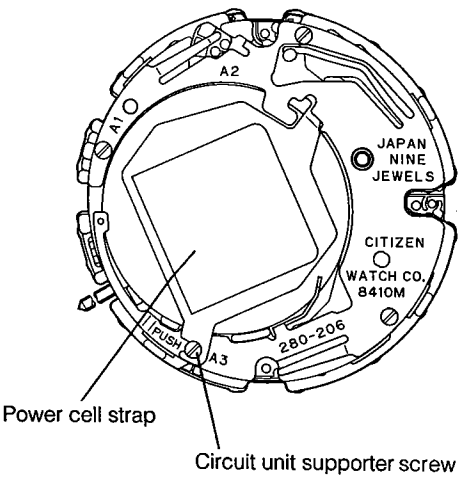
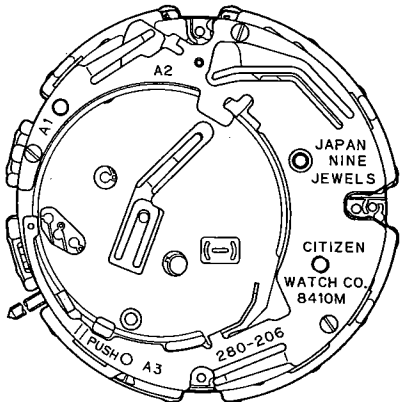
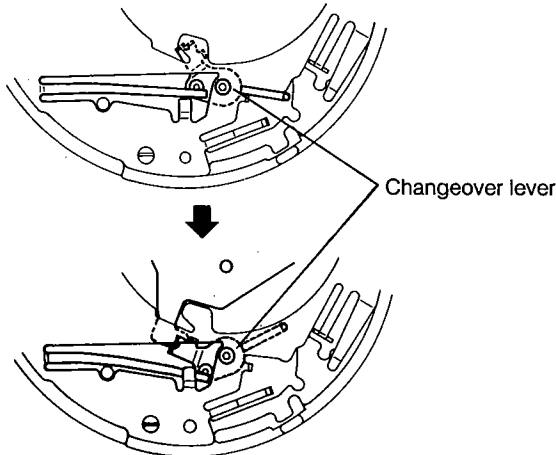
Step	Explanatory Drawing	Precautions
<p>① Remove the power cell strap.</p>	 <p>The diagram shows the back of the watch case with the circuit unit installed. A power cell strap is shown attached to the bottom of the case. A screw is labeled 'Circuit unit supporter screw'. Other labels include 'A1', 'A2', 'A3', 'PUSH O', '280-206', 'JAPAN NINE JEWELS', and 'CITIZEN WATCH CO. 8410M'.</p>	<p>Loosen the circuit unit support screw, then remove the power cell strap.</p> <p>Perform this work in UK or L-TM mode.</p>
<p>② Remove the power cell.</p>	 <p>The diagram shows the back of the watch case with the power cell removed. The circuit unit is still present. Labels include 'A1', 'A2', 'A3', 'PUSH O', '280-206', 'JAPAN NINE JEWELS', and 'CITIZEN WATCH CO. 8410M'.</p>	
<p>③ Install the power cell strap without setting the power cell.</p>	 <p>The diagram shows a close-up of the changeover lever mechanism. A downward arrow indicates the lever being pushed down. The label 'Changeover lever' points to the mechanism.</p>	<p>Push the changeover lever with the power cell strap to install the latter. (See the replacement procedure for the power cell.)</p>

Step	Explanatory Drawing	Precautions
<p>④ Set the tester.</p>	<ul style="list-style-type: none"> • Start with the 10-mA range of the tester, then gradually lower the range to 10 μA. • Set the power cell to the tester. • Set the lead pins of the tester to the module. • Short the reset pattern to the circuit unit supporter. • After all-reset operation, the current consumption increases temporarily. Wait until the current consumption stabilizes, then gradually lower the measurement range of the tester from 10 mA to 10 μA. <div style="border: 1px solid black; padding: 5px; margin-top: 10px;"> <p>* After measuring the power consumption and setting the power cell, adjust the hands to the zero-position and set the time and calendar.</p> </div>	<ul style="list-style-type: none"> • Within standard range → Under normal condition: 1.3 - 1.6 μA • Out of standard range → Check train wheel and dial side mechanism, and remove dirt. • Out of standard range again → Replace unit of electronic circuit.

§15. PRECAUTIONS FOR DISASSEMBLY AND ASSEMBLY

Explanatory Drawing	Precautions
<p>① Antenna screw</p> <p>② Antenna sheet strap</p> <p>Antenna ④</p> <p>★ Case screw hole</p> <p>③ Antenna fixing screws</p>	<p>Remove the case back, then remove the antenna from the case before taking out the module.</p> <p>Since the antenna terminal seat is positioned to the dowel of the circuit unit supporter, take care when removing the antenna. (Take care not to break the antenna terminal seat.)</p> <p>★ Case screw hole Apply a small amount of LOCKTIGHT to the case screw holes when installing the antenna (Medium strength LOCKTIGHT).</p>
<p>Date rotor</p> <p>Third wheel and pinion</p> <p>Fourth wheel and pinion</p> <p>Fifth wheel and pinion</p> <p>Rotor</p> <p>Second rotor</p> <p>Intermediate second wheel</p> <p>Second wheel</p> <p>Intermediate date wheel (2)</p> <p>Intermediate date wheel (1)</p> <p>Date rotor</p>	

§16. DISASSEMBLY AND ASSEMBLY OF MODULE

Disassembly procedure: ① → ⑥⑩
 Assembly procedure: ⑥⑩ → ①

● Lubrication mark

- Ⓐ : A-Lube oil
- Ⓥ : V-Lube oil
- ⓕ : F-Lube oil
- Ⓞ : CH-1 oil

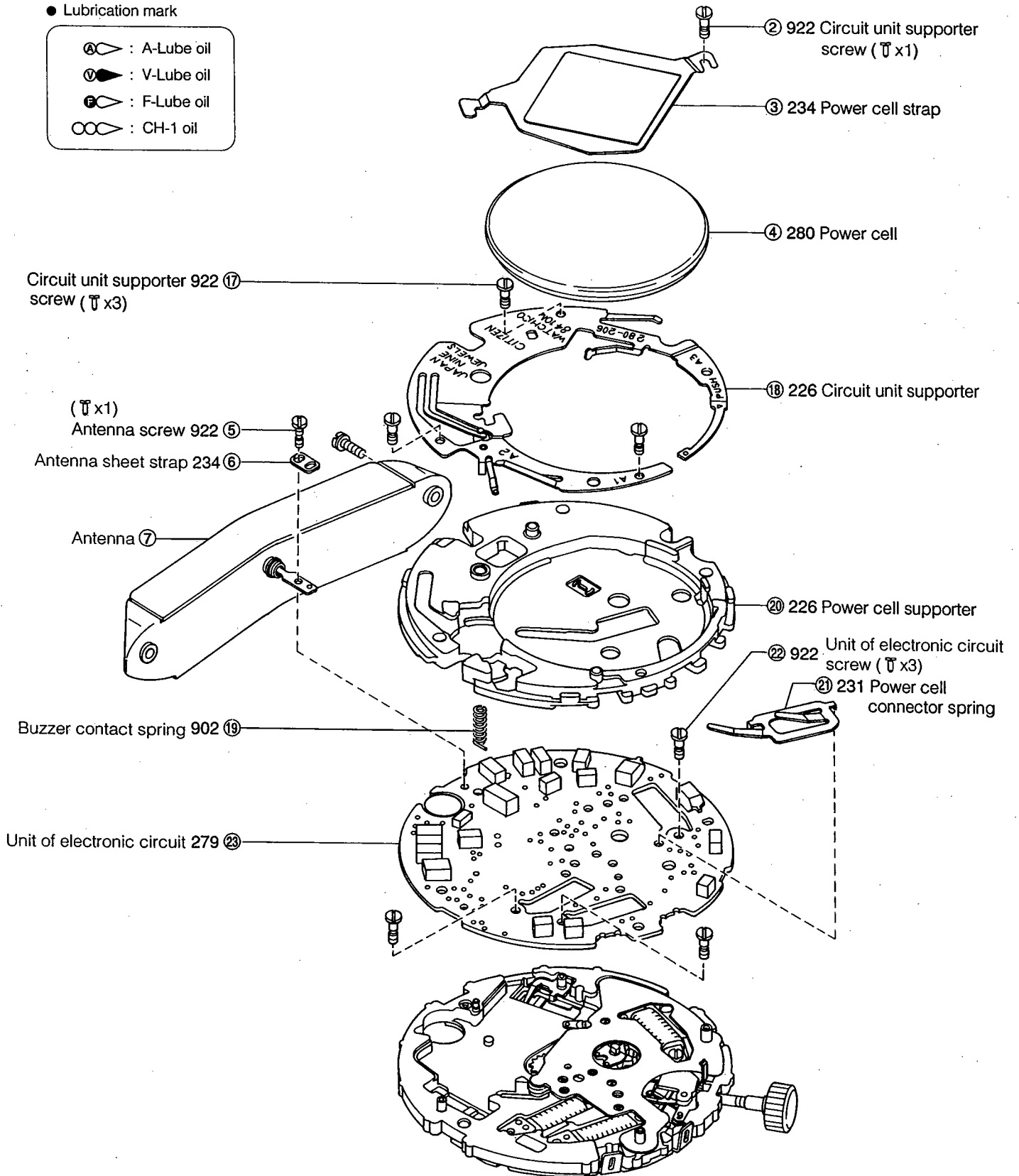

Explanatory Drawing

Precautions

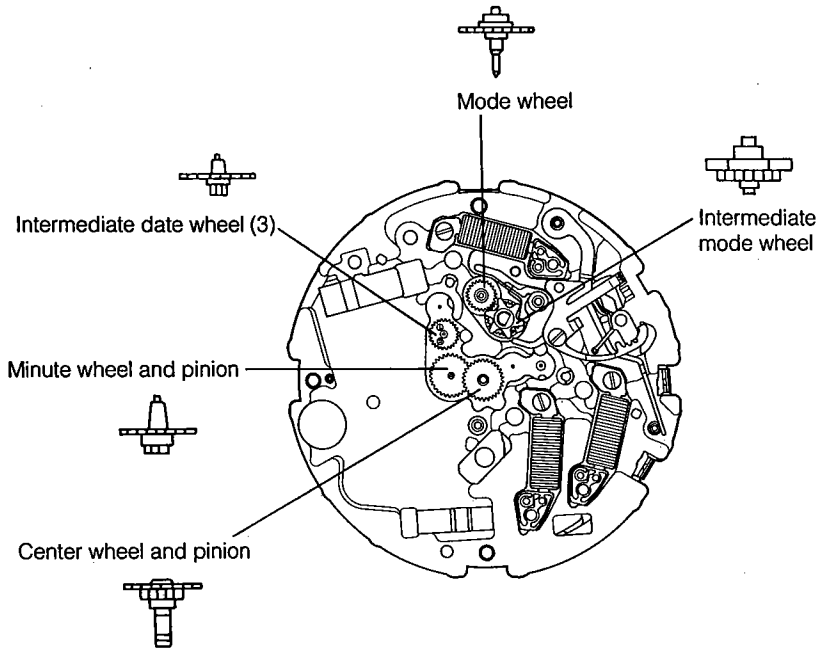

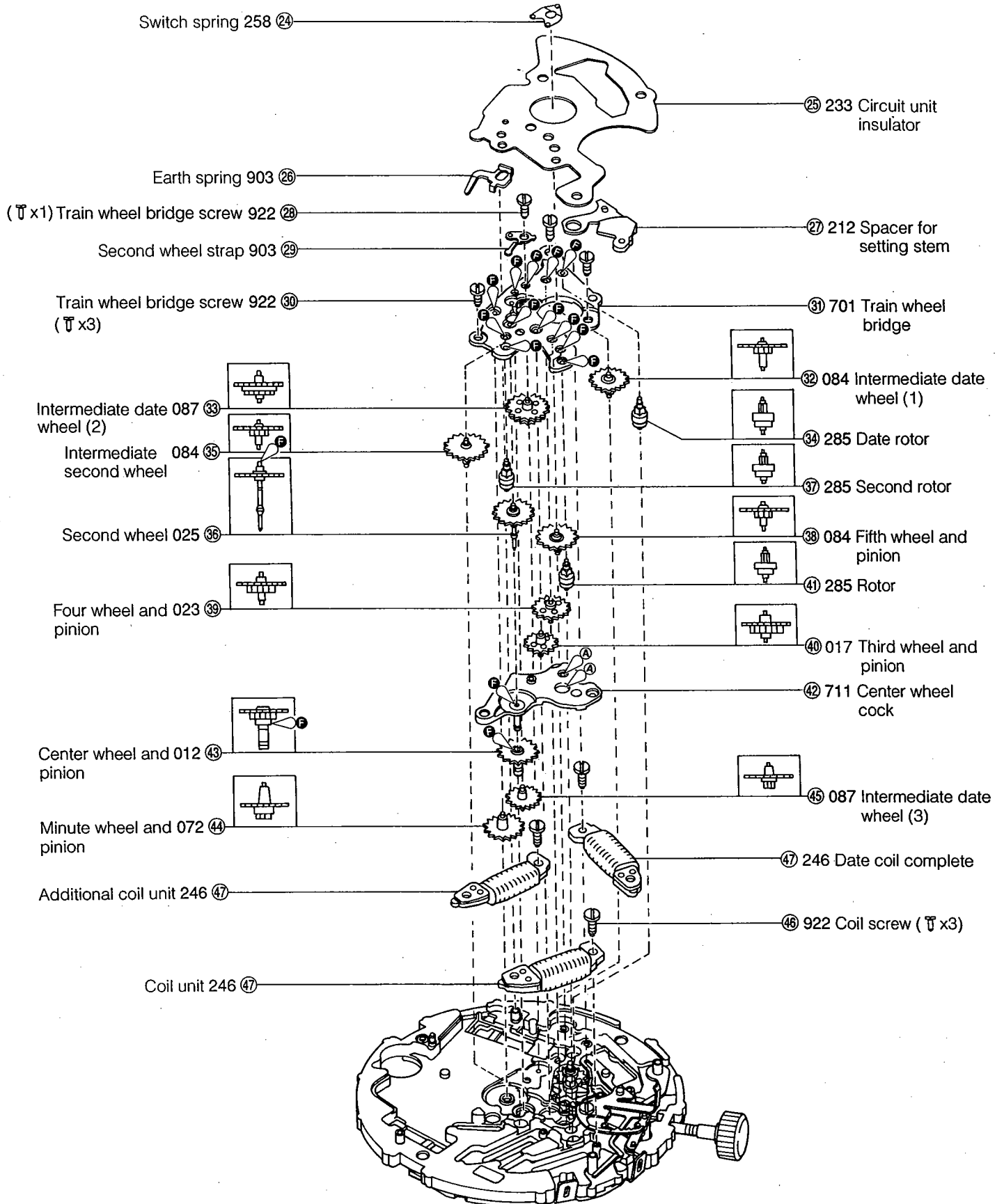

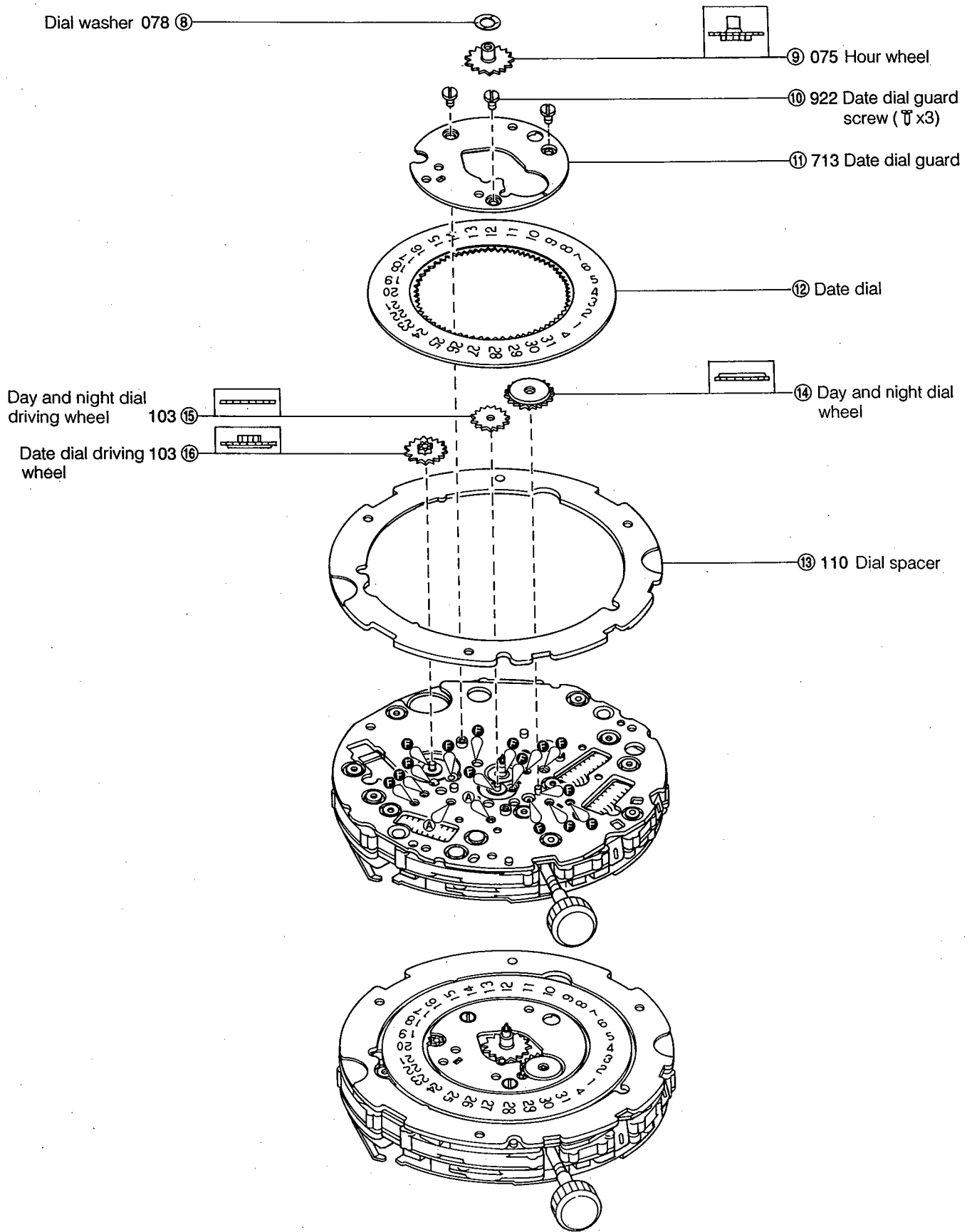

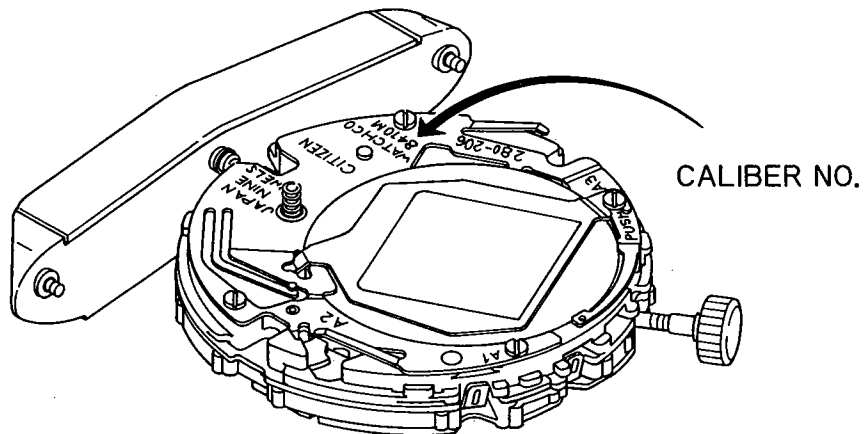
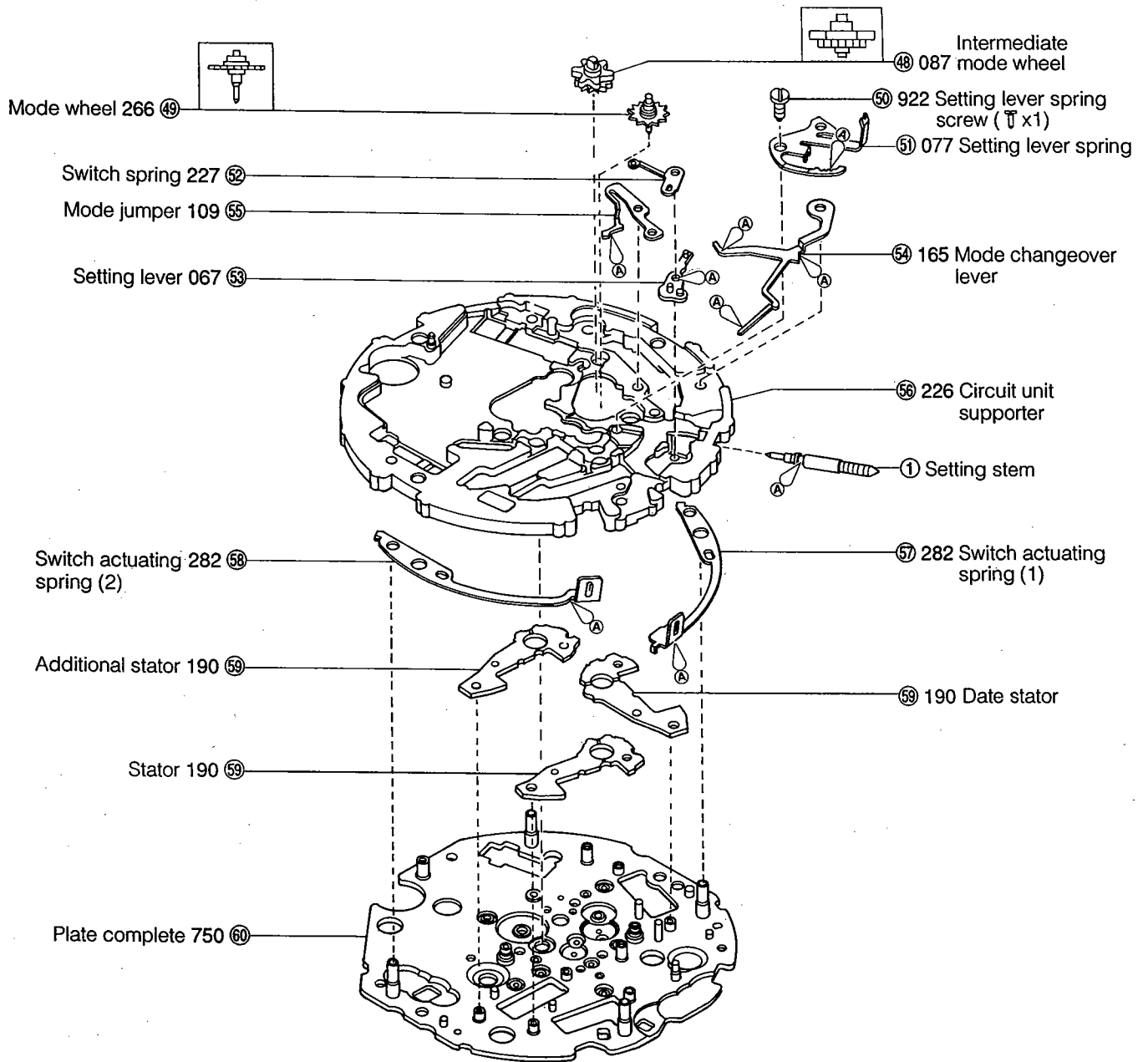

\$17. TROUBLESHOOTING AND ADJUSTMENT

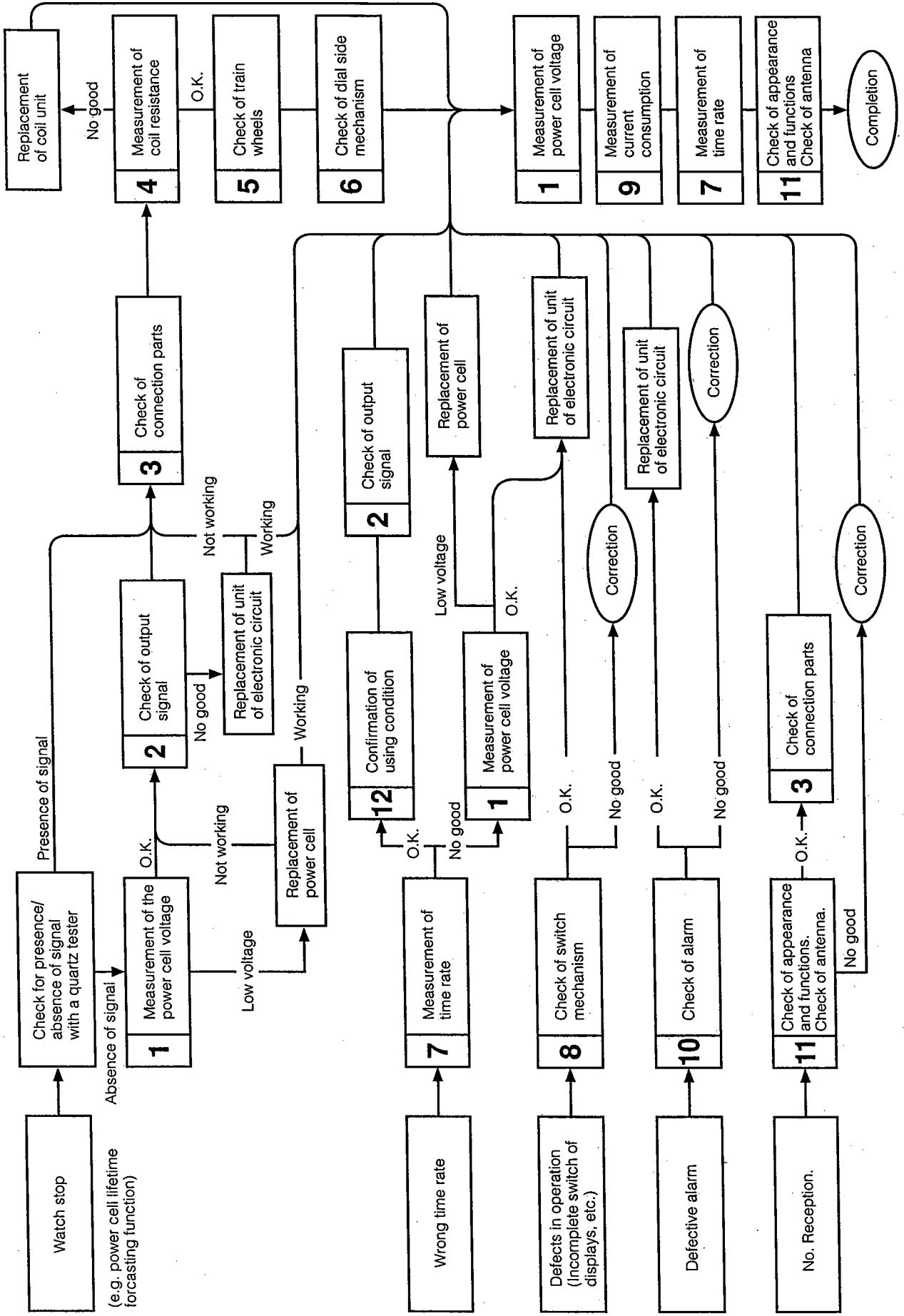

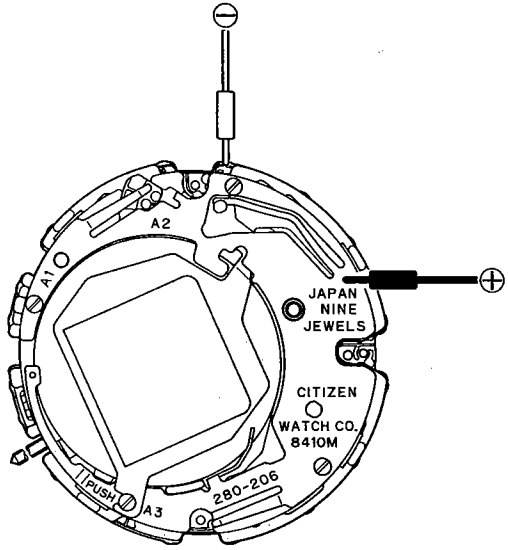
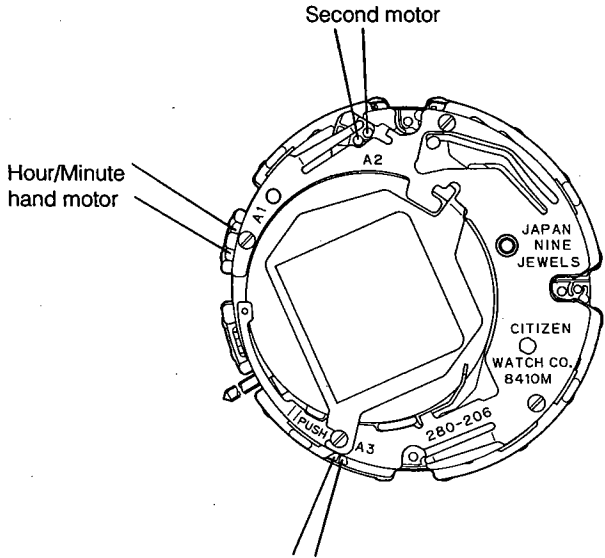
Check Items	How to Check	Results and Treatments
<p>① Measurement of power cell voltage</p>	<p><Refer to Technical Manual, Basic Course: II-1-a> <Tester range: D.C.6V></p> 	<ul style="list-style-type: none"> • More than 3.0 V → Nondefective • Less than 3.0 V → Replace the power cell.
<p>② Check of output signal</p>	<p><Refer to Technical Manual, Basic Course: II-1-b> <Tester range: D.C.0.3V></p> <p>– Preparation for confirmation –</p> <ul style="list-style-type: none"> • Press the M button to select ▶0◀ mode. <p>– Confirmation –</p> <ul style="list-style-type: none"> • Apply the tester lead pins to the output terminals and press the A or B button for at least 1 second, then release it. (The hands move for demonstration.) <p>(The tester lead pins have no polarity.)</p> 	<ul style="list-style-type: none"> • Tester pointer swings → Nondefective • Tester pointer does not swing → Replace the unit of electronic circuit.

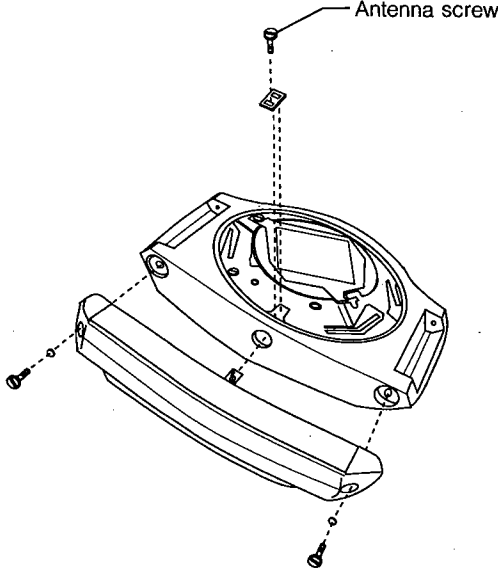
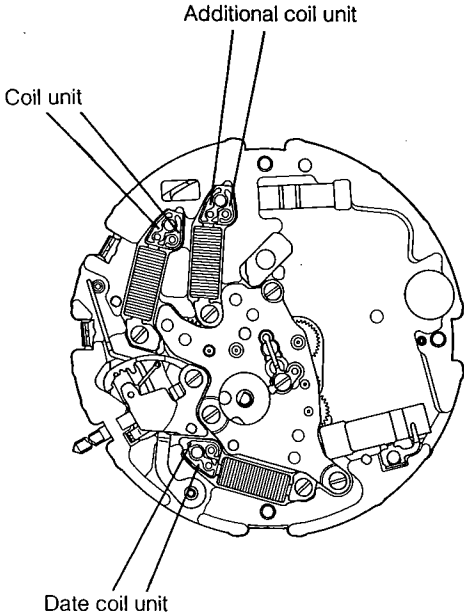
Check Items	How to Check	Results and Treatments
<p>③ Check of connection parts</p>	<p><Refer to Technical Manual, Basic Course: II-2-a, Analog section></p> <ul style="list-style-type: none"> • Confirm that the antenna screw is not broken or loosened. Breakage and looseness of the screw have bad effects on receiving sensitivity.  <p>The diagram shows a perspective view of the device's chassis with the top cover removed. A dashed line points from the label 'Antenna screw' to a screw on the top surface of the chassis. Another dashed line points to a screw on the side of the chassis.</p>	<ul style="list-style-type: none"> • The antenna screw is broken or cracked → Replace.
<p>④ Measurement of coil resistance</p>	<p><Refer to Technical Manual, Basic Course: II-1-c> <Tester range: R x 10></p> <p>– Preparation for measurement –</p> <ul style="list-style-type: none"> • Remove the unit of electronic circuit before measuring the coil resistance. <p>– Measurement –</p> <ul style="list-style-type: none"> • The tester lead pins have no polarity.  <p>The diagram shows a top-down view of the internal coil unit assembly. It features two main components: a 'Coil unit' and an 'Additional coil unit'. A 'Date coil unit' is also indicated at the bottom. The assembly includes various electronic components like capacitors and resistors, and is mounted on a circular printed circuit board.</p>	<ul style="list-style-type: none"> • Resistance of each coil is 2.02 kΩ - 2.38 kΩ → Nondefective • Out of above range → Coil unit is defective.

Check Items	How to Check	Results and Treatments
5 Check of train wheels	<p><Refer to Technical Manual, Basic Course: II-2-b></p> <ul style="list-style-type: none"> • Check the gears and rotors for dust and oil. • Check the plastic gears and pinions for crashing, deformation, bend of shaft, etc. 	
6 Check of dial-side mechanism	<p><Refer to Technical Manual, Basic Course: II-2-c></p> <ul style="list-style-type: none"> • Check the parts for deformation and confirm that they are lubricated well. 	
7 Measurement of time rate	<p><Refer to Technical Manual, Basic Course: II-2-c> <Measurement range: Analog 10 seconds></p> <p>– Preparation for measurement –</p> <ul style="list-style-type: none"> • Press the M button to select EUR, UK, JPN or L-TM mode. <p>– Measurement –</p> <ul style="list-style-type: none"> • The time rate cannot be adjusted. 	<ul style="list-style-type: none"> • Standard time rate → -0.2 ~ 0.6 sec/day • Out of standard range → Replace the power cell or unit of electronic circuit.
8 Check of switch mechanism	<p>① Check of movement</p> <ul style="list-style-type: none"> • Push the switch actuating spring with tweezers, etc. to bring it contact with the pattern of the unit of electronic circuit to confirm the switching function. • Check for removal of the pattern from the unit of electronic circuit and the switch actuating spring for deformation. <p>② Check of push buttons</p> <ul style="list-style-type: none"> • Check the push buttons for deformation and dirt. <div style="border: 1px solid black; border-radius: 10px; padding: 5px; margin-top: 10px;"> <p>Note: Apply silicone oil to the packings of the push buttons without fail. It is necessary for maintenance of water resistance and smooth operation.</p> </div>	<ul style="list-style-type: none"> • No problems in switch mechanism → Check the push buttons. • Any push button is dirty or deformed → Clean or replace the push button.
9 Measurement of current consumption	<p>See "§14. Measurement method for current consumption".</p>	

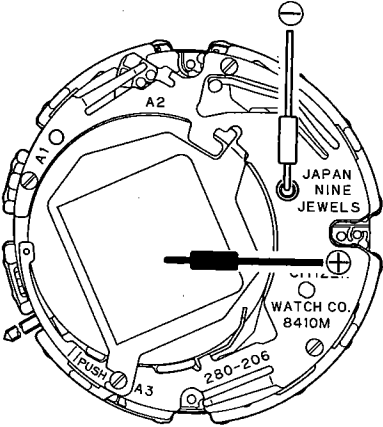
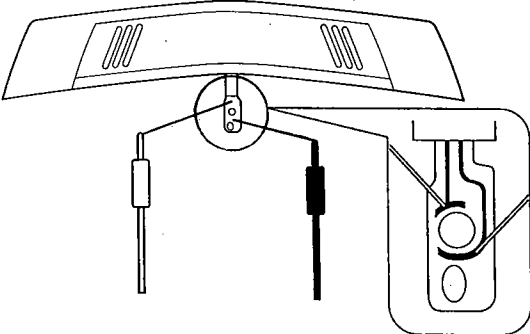
Check Items	How to Check	Results and Treatments
<p>⑩ Check of alarm</p>	<p><Refer to Technical Manual, Basic Course: II-1-d></p> <p>– Preparation for check –</p> <p>① Set the module in the case with the case back removed.</p> <p>② Push the (M) button to select "ALM" mode.</p> <p>– Check –</p> <p>③ Apply the positive \oplus lead pin to the power cell surface and the negative \ominus lead pin to the buzzer contact spring, and push and hold the (B) button.</p>  <p>④ If the alarm output is normal, perform the following checks.</p> <ul style="list-style-type: none"> • Check the piezo-electric element of the vibrating plate for cracking and breakage. • Check the buzzer contact spring for bend and deformation. 	<ul style="list-style-type: none"> • Tester pointer does not swing → Check the alarm output spring for floating. <p style="text-align: center;">↓</p> <p>Replace the unit of electronic circuit.</p> <ul style="list-style-type: none"> • Tester pointer swings → Nondefective <p style="text-align: center;">↓</p> <p>Go to ④.</p> <p style="text-align: center;">↓</p> <p>If no defects are found, the alarm function is normal</p> <p>Install the buzzer contact spring correctly.</p>
<p>⑪ Check of appearance and functions</p> <p>Check of antenna</p>	<p><Refer to Technical Manual, Basic Course: II-2-f></p> <ul style="list-style-type: none"> • Confirm that each correcting switch works normally. • Check the antenna for breakage. Shake the watch to check for clatter. • Check the continuity of the antenna seat of the antenna unit.  <p><Tester range: R x 1></p>	<ul style="list-style-type: none"> • Tester pointer swings → Nondefective • Tester pointer does not swing → Replace the antenna.
<p>⑫ Confirmation of using condition</p>	<p><Refer to Technical Manual, Basic Course: II-2-e></p>	